



Design of Robotic Milking Systems in the Southeast US



JGM  , Inc.
Dairy Design Engineers

Joseph G. "Jake" Martin III, P.E., M.S., Owner/President
Rachael B. Kent, P.E., M.S., Engineering Project Mgr.

Why Consider Robotic Milking Systems?



Existing conventional parlor worn out?



Looking to reduce labor costs and increase efficiencies?



Desire more free time/flexible work hours?



Cow health/data collection

Interested in a Voluntary Robotic Milking System?



What is your desired barn design?

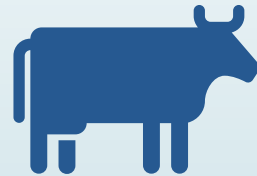

What is your desired cow flow design?



What is your desired return on investment?



What is your desired barn design?

Natural/tunnel ventilated barns

4 or 6 row freestall barn

Central or perimeter feed drive lane

Natural vs. Tunnel Ventilated Barns

- ▶ Tunnel Barns approx. 40% more expensive
- ▶ Naturally ventilated barns do well in Southeast US
- ▶ Challenges to ventilating around robotic milking units/operating pits





What is your desired barn design?

Natural/tunnel ventilated barns

4 or 6 row freestall barn

Central or perimeter feed drive lane

4 or 6 Row Barn? Feed drive location?

- ▶ Cost difference?
- ▶ Feed face difference?
- ▶ Can affect overall cow flow decision

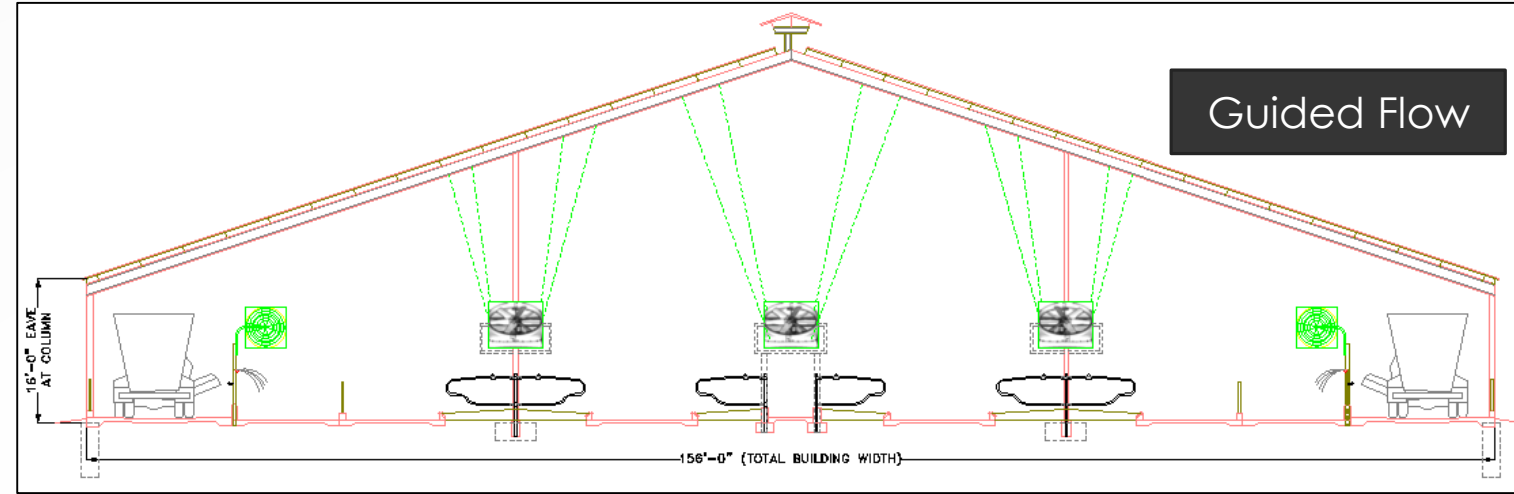

Hybrid
Guided Flow

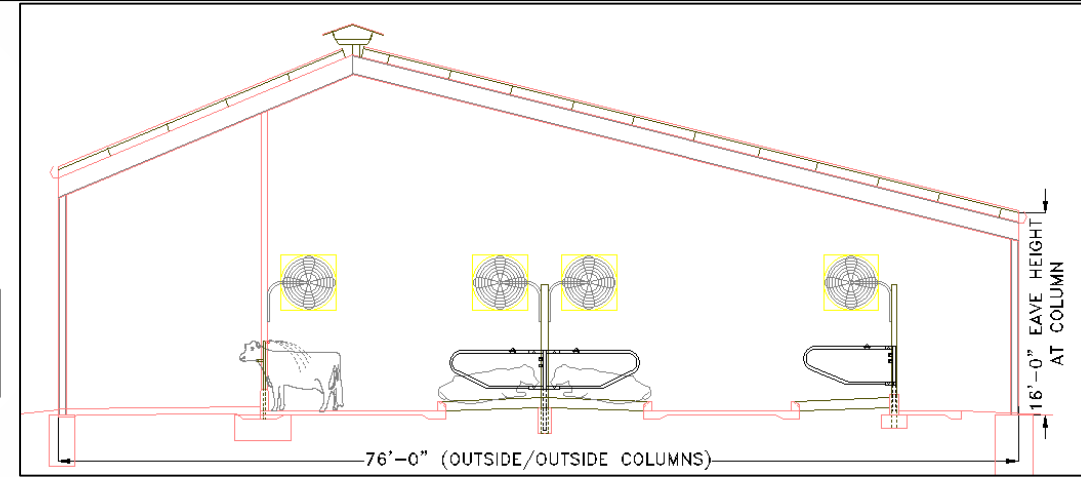

Free Flow

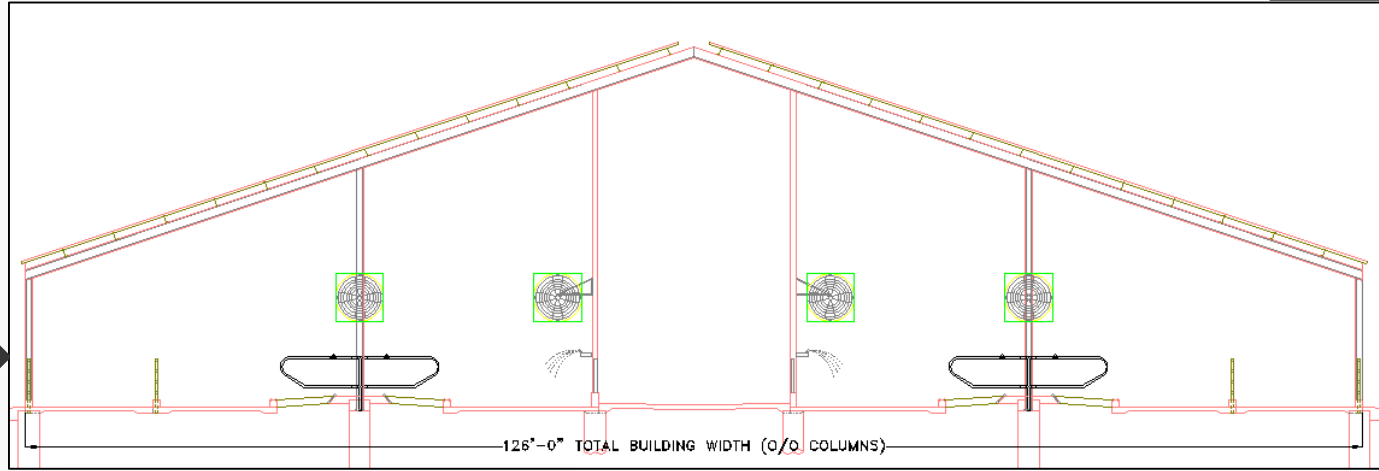

Interested in a Voluntary Robotic Milking System?



What is your desired barn design?

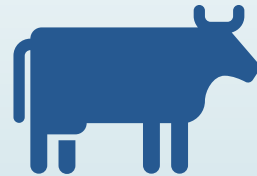

What is your desired cow flow design?



What is your desired return on investment?



What is your desired cow flow design?

Guided flow

Free flow

Hybrid flow

Cow Flow Design: Guided Flow

- Higher initial cost
- Lower labor cost
- Lowest refusal rate
- Highest level of management control

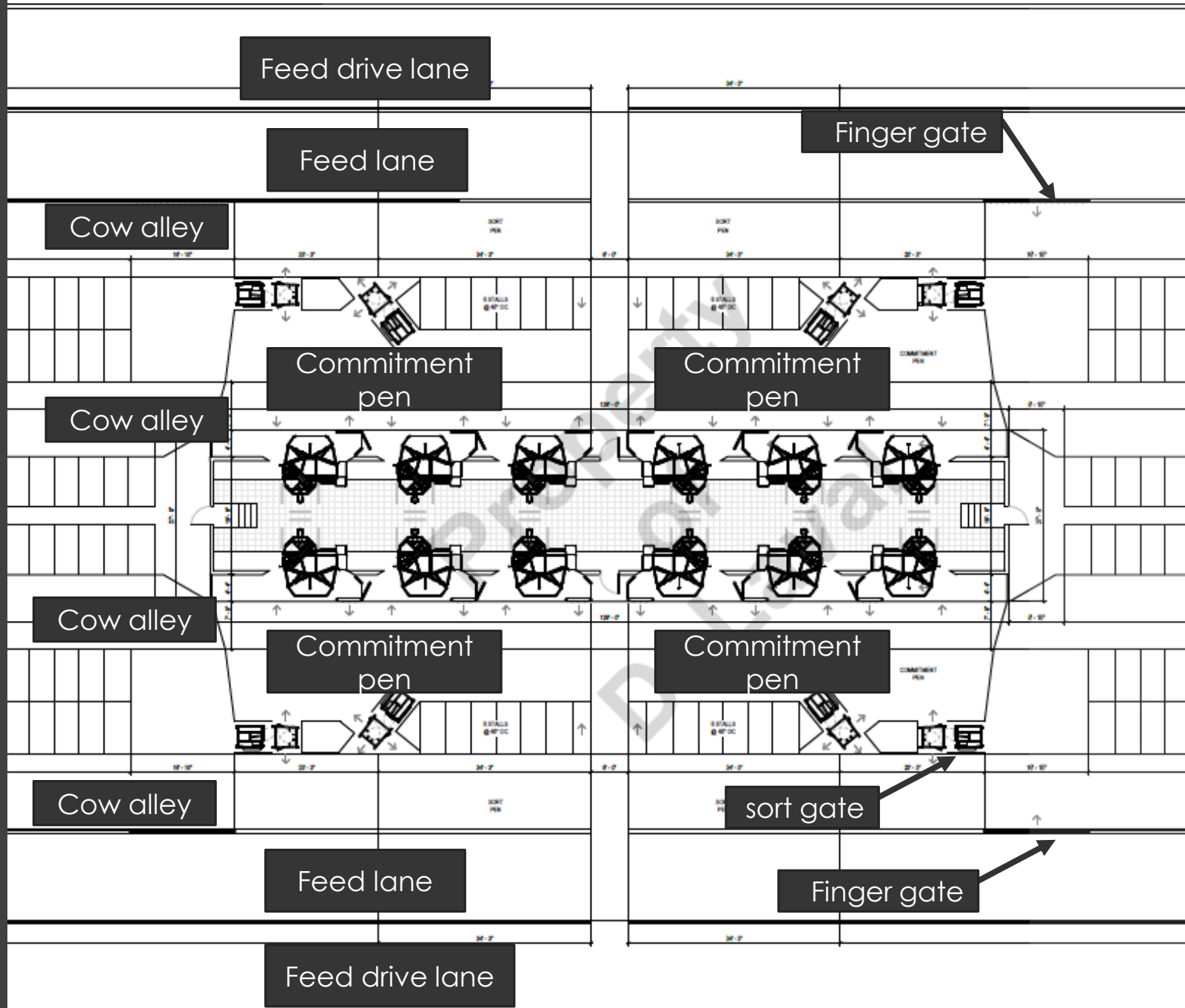

Types of Guided Flow Design



FEED FIRST OPTION



MILK FIRST OPTION

Guided Flow - Feed First Option

- Approx. 8-12lb/cow/day grain in robot
- Cows access feed face via finger gates
- Cows access robot after entering feed lane

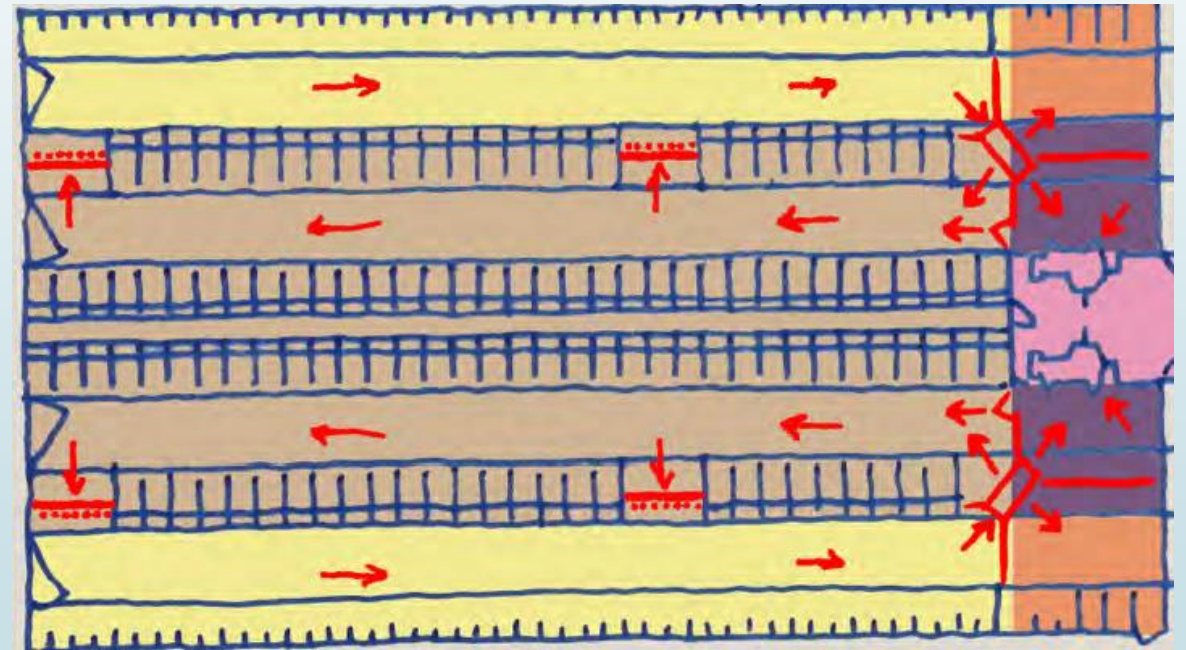
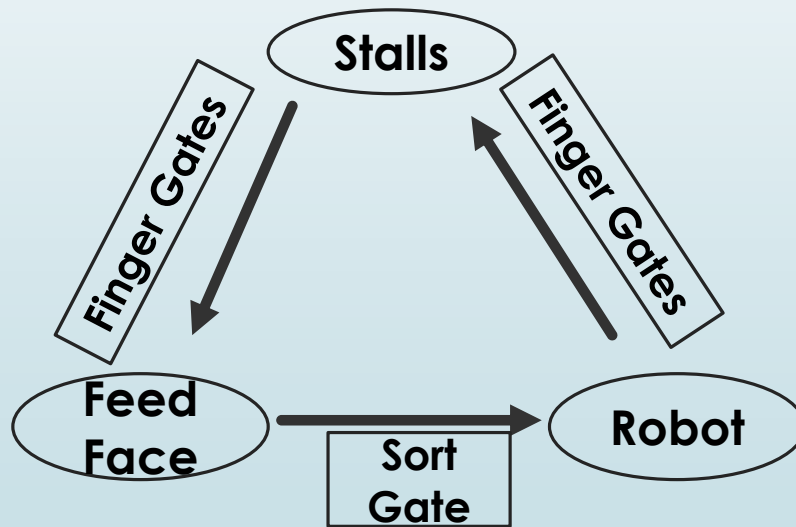

Copyright Delaval 2014

Guide Flow - Milk First Option

- Approx. 3-4lb/cow/day grain in robot
- Cows must walk through sort gate to gain access to either robot or feed face

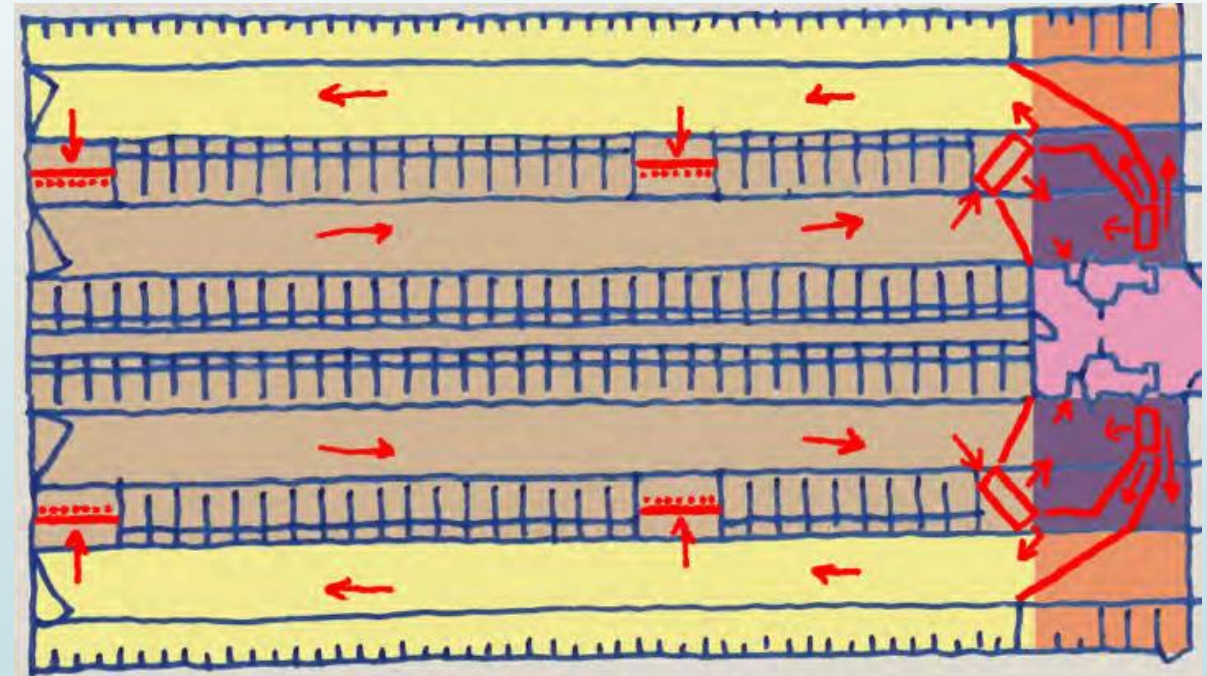
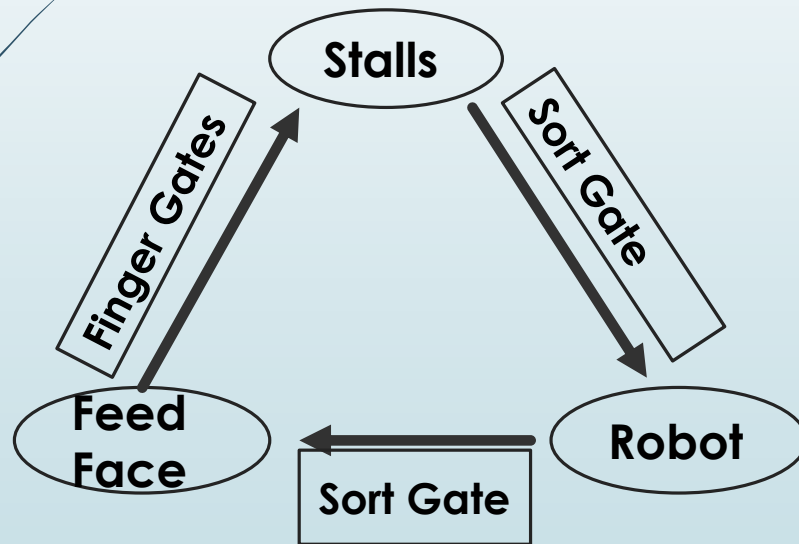

Copyright Delaval 2014



What is your desired cow flow design?

Guided flow

Free flow

Hybrid flow

Cow Flow Design: Free Flow

- ▶ Lowest initial cost
- ▶ Highest labor cost
- ▶ Highest refusal rate
- ▶ Lowest level of management control

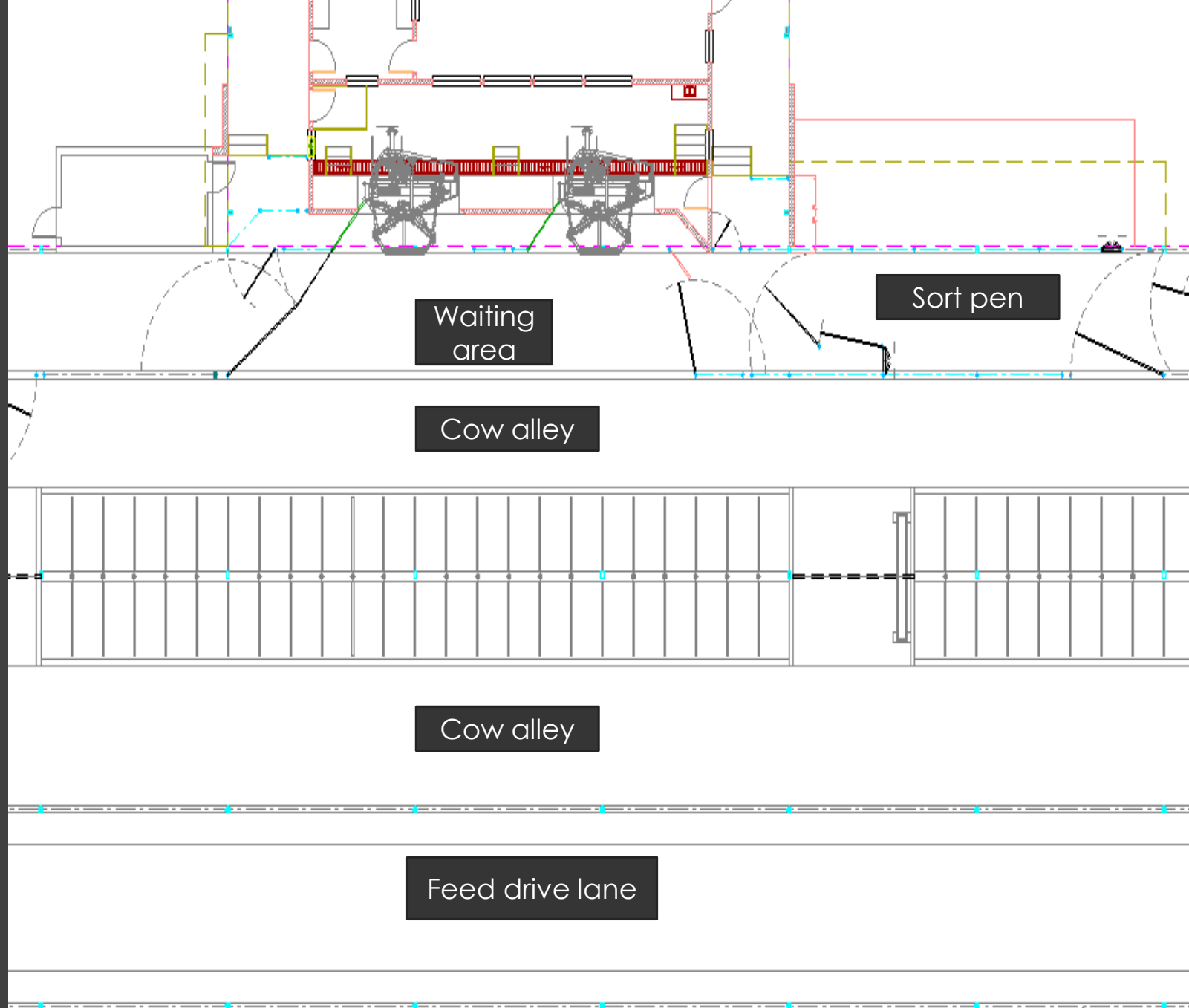
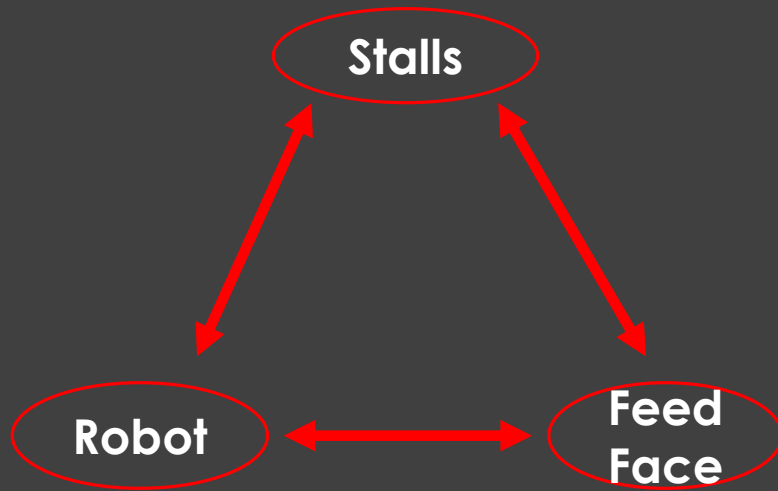



What is your desired cow flow design?

Guided flow

Free flow

Hybrid flow

Cow Flow Design: Hybrid Flow

- Moderate initial cost
- Moderate labor cost
- Moderate refusal rate
- Moderate level of management control

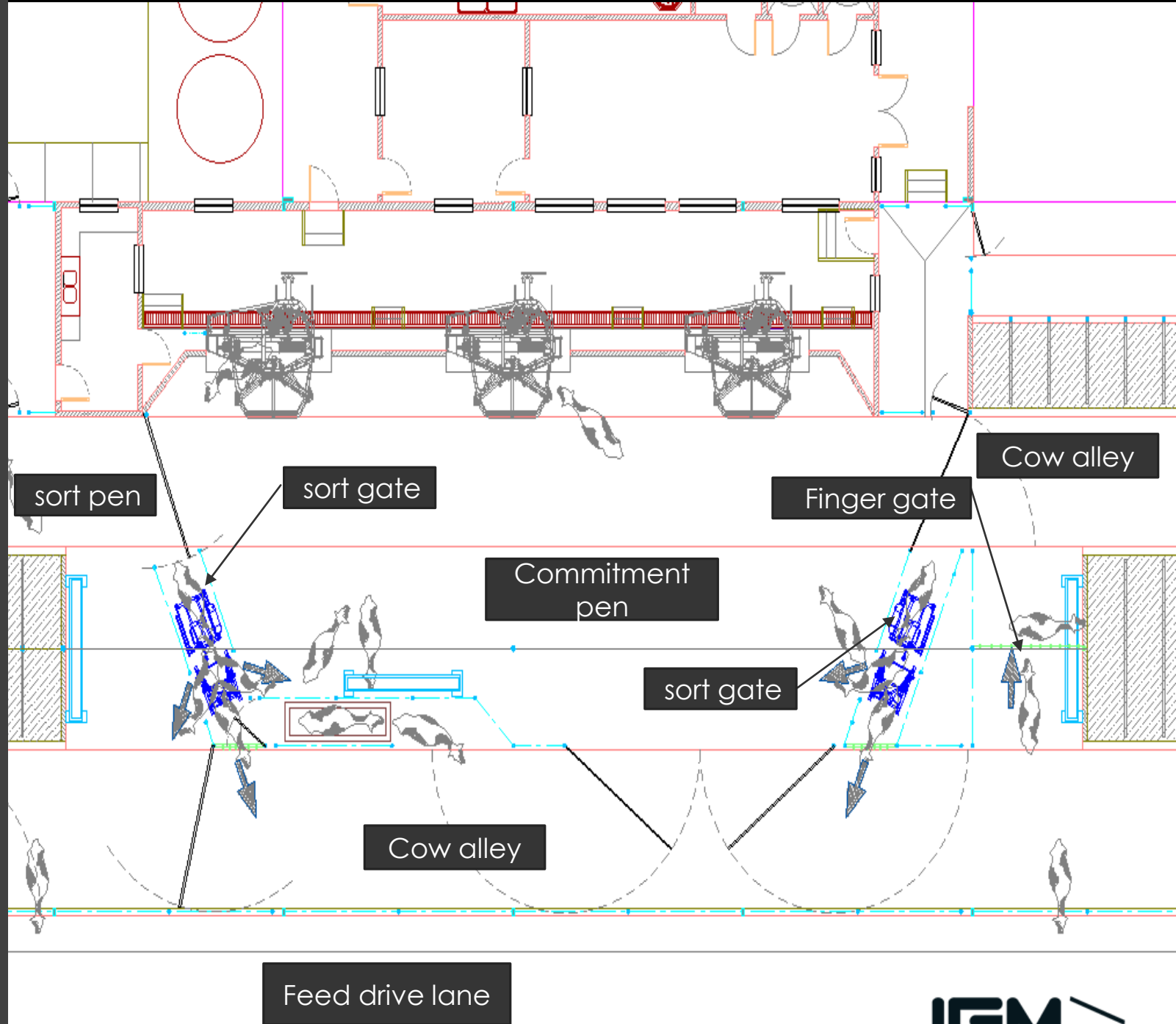
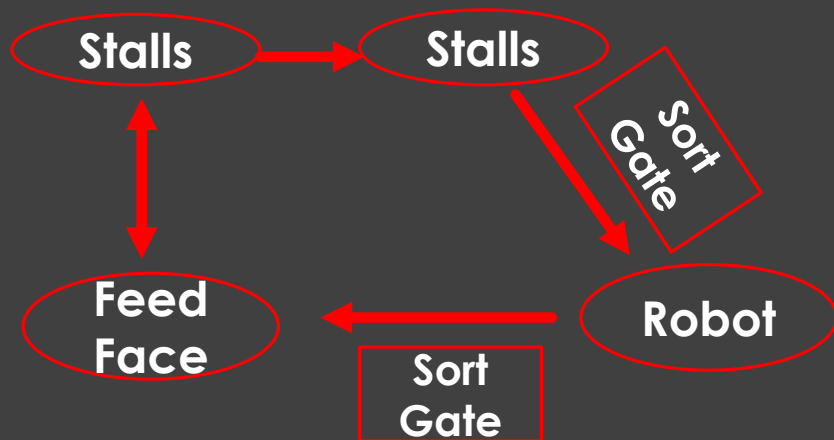

Guided vs. Free vs. Hybrid Flow

Cow Flow Design	Initial Investment	Labor Costs	Feed Costs	Refusal Rates	Management Control
Guided	Highest	Lowest	Lowest	Lowest	Highest
Hybrid	Middle	Middle	Middle	Middle	Middle
Free	Lowest	Highest	Highest	Highest	Lowest

Ultimate deciding factor: management philosophy

Interested in a Voluntary Robotic Milking System?



What is your desired barn design?

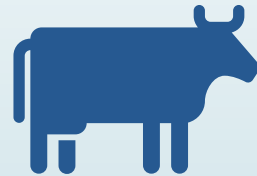

What is your desired cow flow design?



What is your desired return on investment?



What is your desired return on investment?

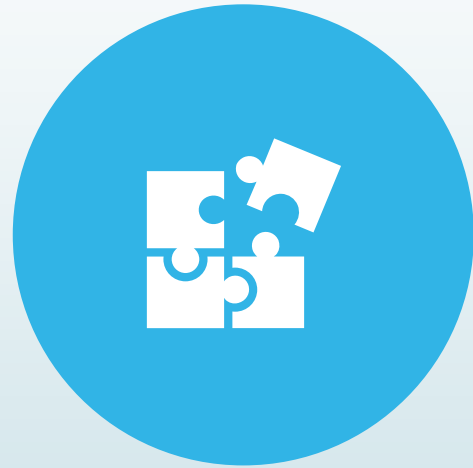

RETROFIT?



NEW BUILD?

Retrofit vs. New Build

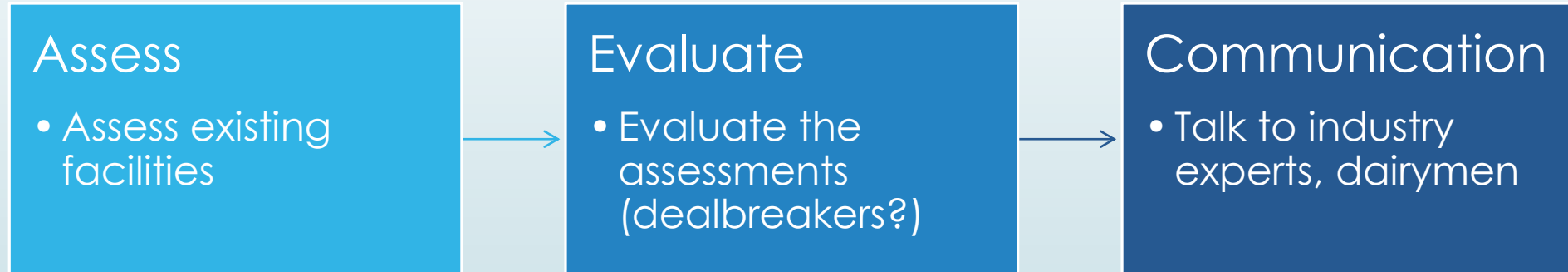

Retrofit vs. New Build



Cooling/Ventilation design



Freestall barn design

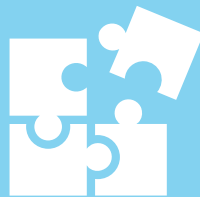

Location for robots/gates etc.

Assess
existing
facilities

Retrofit Dealbreakers?



Evaluate Assessments from Step 1



Retrofit vs. New Build



Other Dairymen



Designers



Manufacturers

Talk To
Others



What building components and equipment do these type of barns consist of?

Design Components for Robotic Milking Barns - Building Components

➤ Milk House

➤ Common Room Types

- Milk Room
- Equipment Room
- VMS/Robot Room
- Toilets (ADA)
- Herdsman's office
- Viewing room
- Storage closets

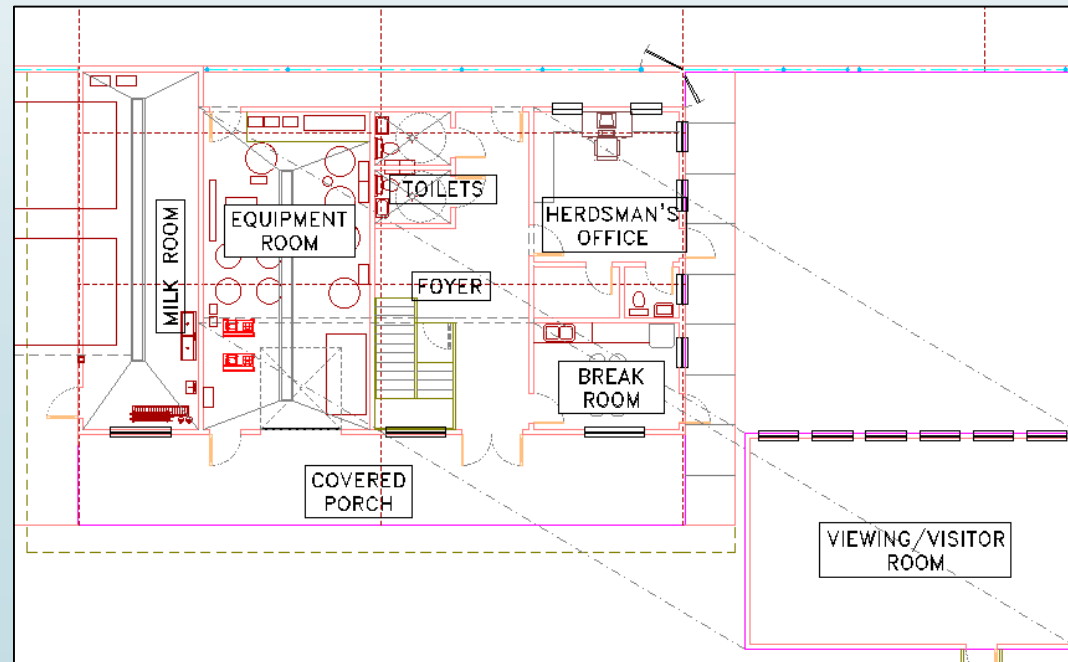
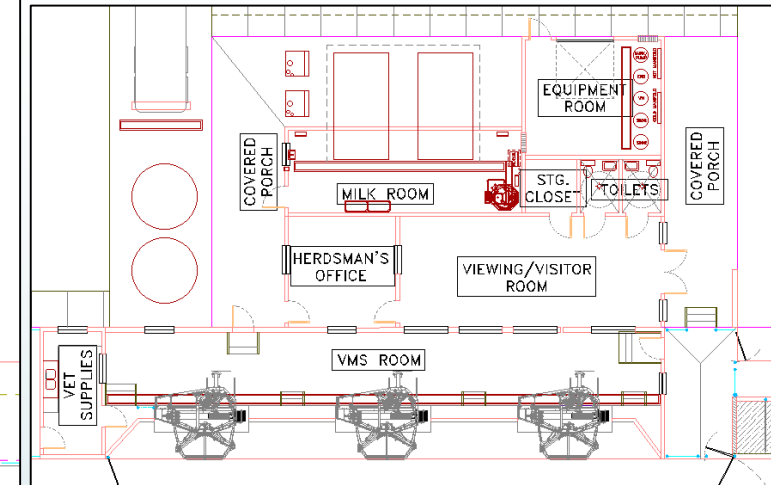
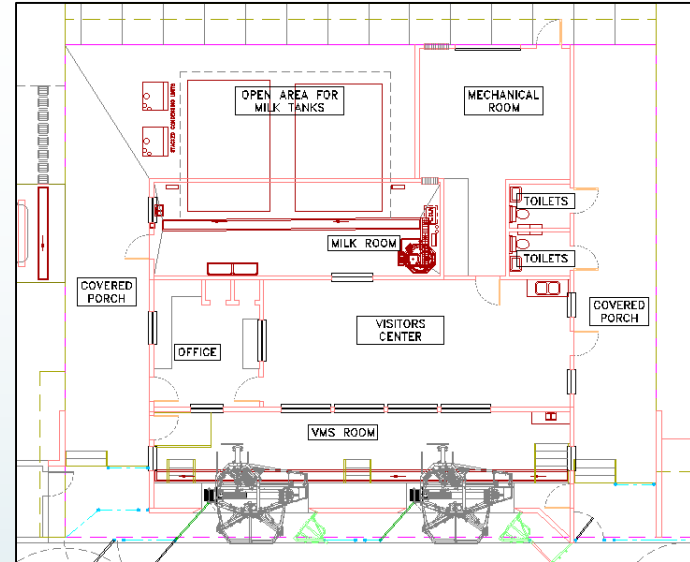

Design Components for Robotic Milking Barns - **Building Components**

➤ **Milk Room**

- Similar to conventional parlor milk rooms
- Encourage use of at least (2) tanks (backup plan)



Design Components for Robotic Milking Barns - **Building Components**

► **Equipment Room**

- Vacuum Pumps
- Water heaters
- Air compressors
- Air tanks
- Water storage tanks
- Electrical panels
- Refrigeration compressors
- Chemicals



Design Components for Robotic Milking Barns - **Building Components**

- **Robotic milking unit room**
 - Positive pressure ventilation in VMS rooms
 - Size based upon equipment mfg. recommendations for robots
 - Operator pit depth
 - Range of 7-28" (depends upon mfg.)



Design Components for Robotic Milking Barns - **Building Components**

➤ Robotic Platform

- **No** steps, ramps ONLY in and out of unit
- Equipotential plane-stray voltage



Design Components for Robotic Milking Barns – **Building Components**

- ▶ **Commitment pens** (guided/hybrid flow)
- ▶ **Fetch pens** (free flow)



Design Components for Robotic Milking Barns – **Building Components**

- ▶ **Separation Pen/Exception Cow Pen**
 - ▶ Sort pen after robot
 - ▶ Can be short or long term

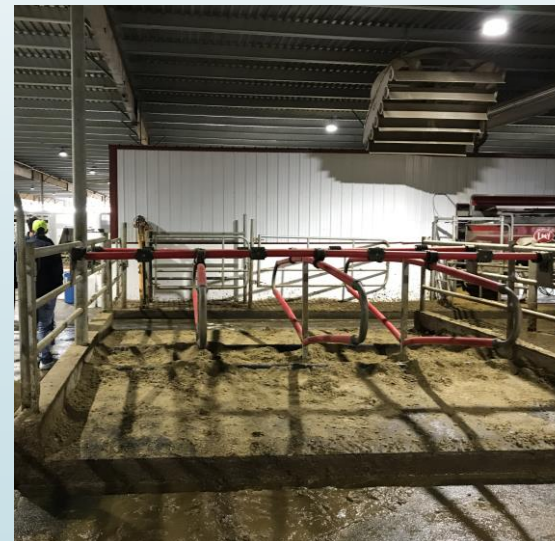
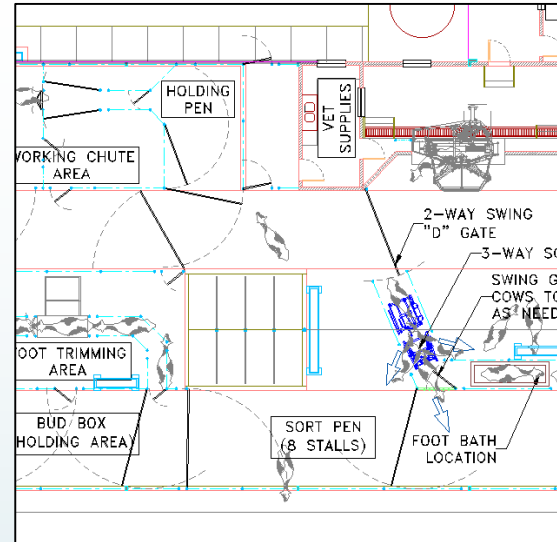

Design Components for Robotic Milking Barns - **Equipment**

- **Voluntary Milking Unit**
 - Building is designed around chosen manufacturer



Design Components for Robotic Milking Barns - **Equipment**

- **Finger gates** - guided and hybrid flow designs
- **NOTE:** Prefer placement in middle of crossover-allows cows from both sides access to water trough



Design Components for Robotic Milking Barns - **Equipment**

- ▶ **Counterbalance gates** – free flow designs
 - ▶ Assist with bedding application/cleaning stalls



Design Components for Robotic Milking Barns - **Equipment**

- **Sort gates/Smart Selection gates**
 - Preselection sort gate



Design Components for Robotic Milking Barns - **Equipment**

- **Sort gates/Smart Selection gates**
 - Post milking sort gate



Design Components for Robotic Milking Barns - **Equipment**

- **Exit gates at Robots**
 - Prevent cows from entering robot via exit



Design Components for Robotic Milking Barns - Equipment

- ▶ D-swing gates at exit sort gates
 - ▶ For dual purpose sort gates

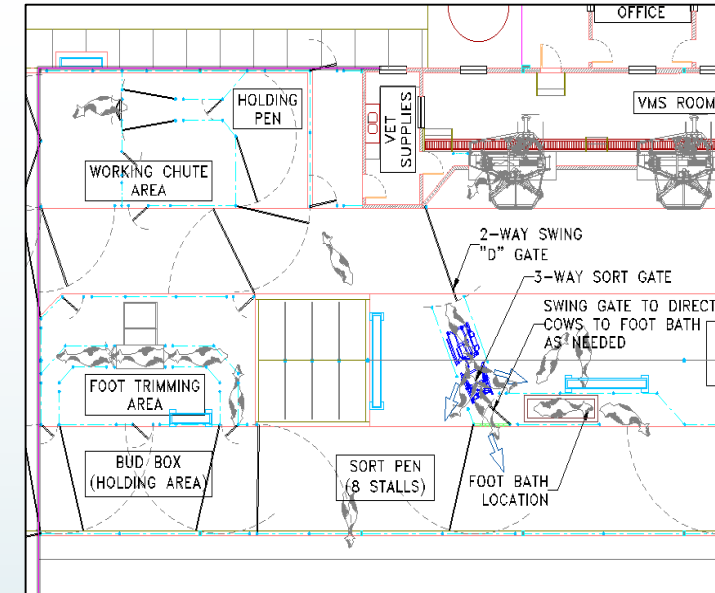
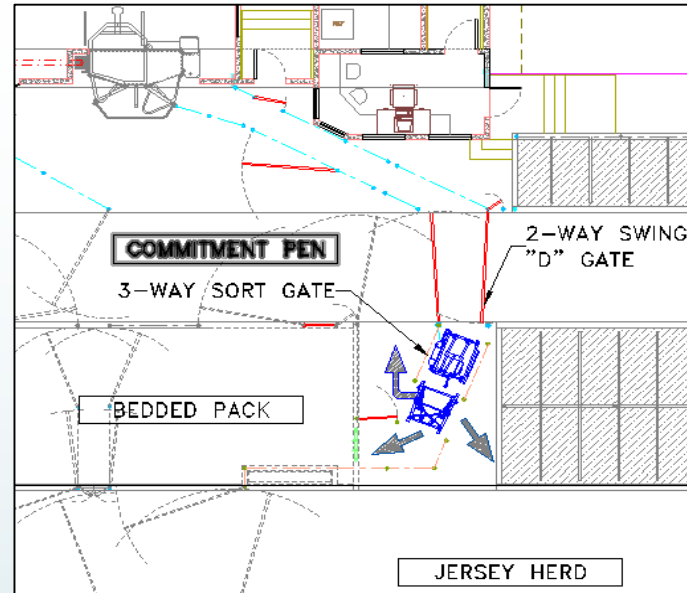



Possible design challenges...

Challenges to Robotic Milking Barn Designs

Where to work cattle:

- ▶ Existing facilities can be used (existing parlors/working areas)
- ▶ New build-place management rails/head catch/foot trimming areas next to sorted pen (post milking sort gate)



Challenges to Robotic Milking Barn Designs

Manure Management System:

- ▶ When to apply bedding?
- ▶ When to clean beds/scrape floors (if applicable)?
- ▶ Scrape vs. flush system?



Challenges to Robotic Milking Barn Designs

Foot Bath location:

- ▶ After the post milking sort gate (guided flow or hybrid free flow only)
- ▶ At the last barn cross over (requires more labor)
 - ▶ Perfect time to apply bedding to stalls
- ▶ Avoid placing in or near the robotic milking unit





Design examples

New Build - **Hybrid Flow:** Hickory Hill Milk, Edgefield, SC

- 3 robots for 196 milking cows
- 2-way pre-selection sort gate
- 3-way dual purpose pre/post selection sort gate
- Commitment pen/finger gates

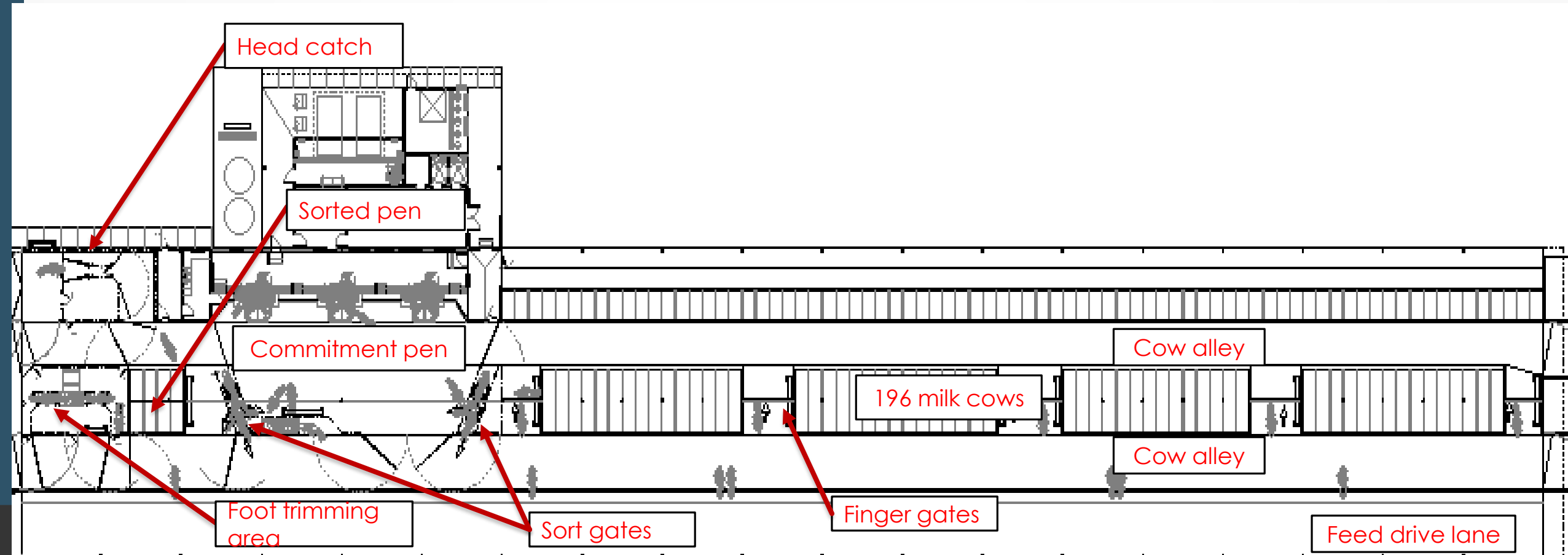

New Build- Hybrid Flow: Martin Dairy, Bowersville, GA

- 4 robots for 256 milking cows
- (2) outer feed lanes
- Centralized VMS room
- (2) pre-selection gates and (2) dual purpose pre/post selection sort gates
- Far-off and Close-Up dry cow stalls/maternity bedded pack
- Working area with head catch
- (2) 8 stall exception cow pens
- (2) commitment pens

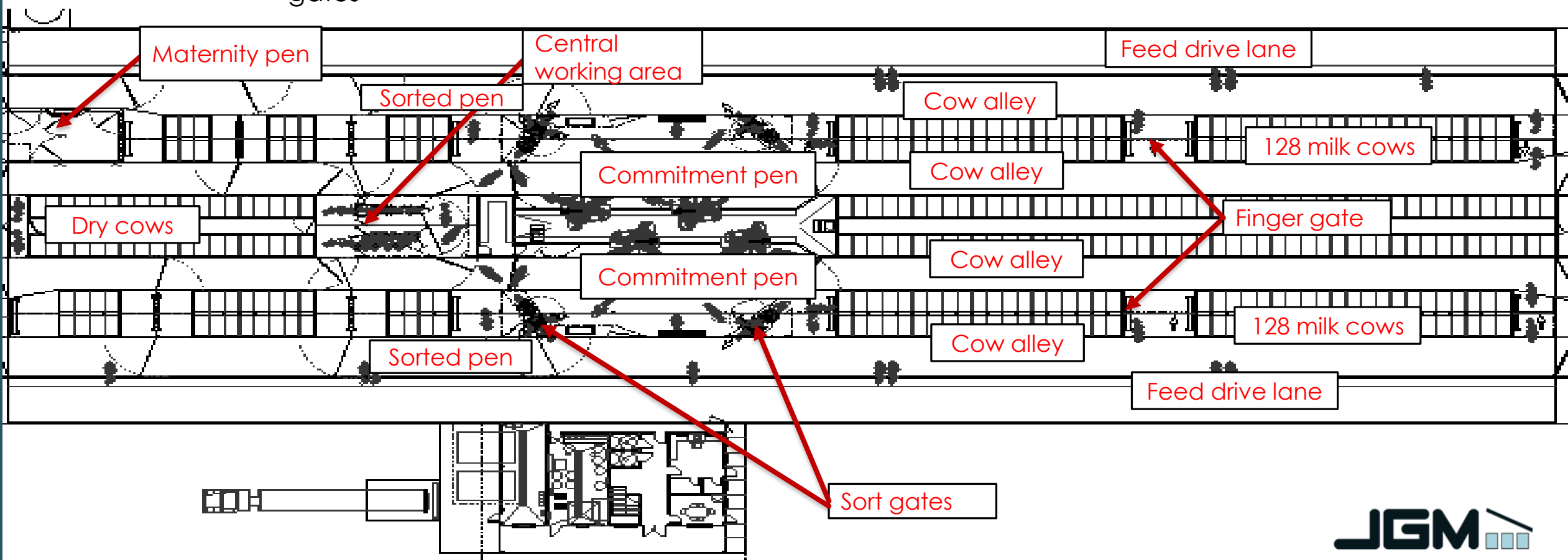

New Build- Milk First Guided Flow Option: Martin Dairy, Bowersville, GA

- Same as hybrid with addition of (2) outer feed lanes
- Finger gates relocated to feed lane, out of cross overs

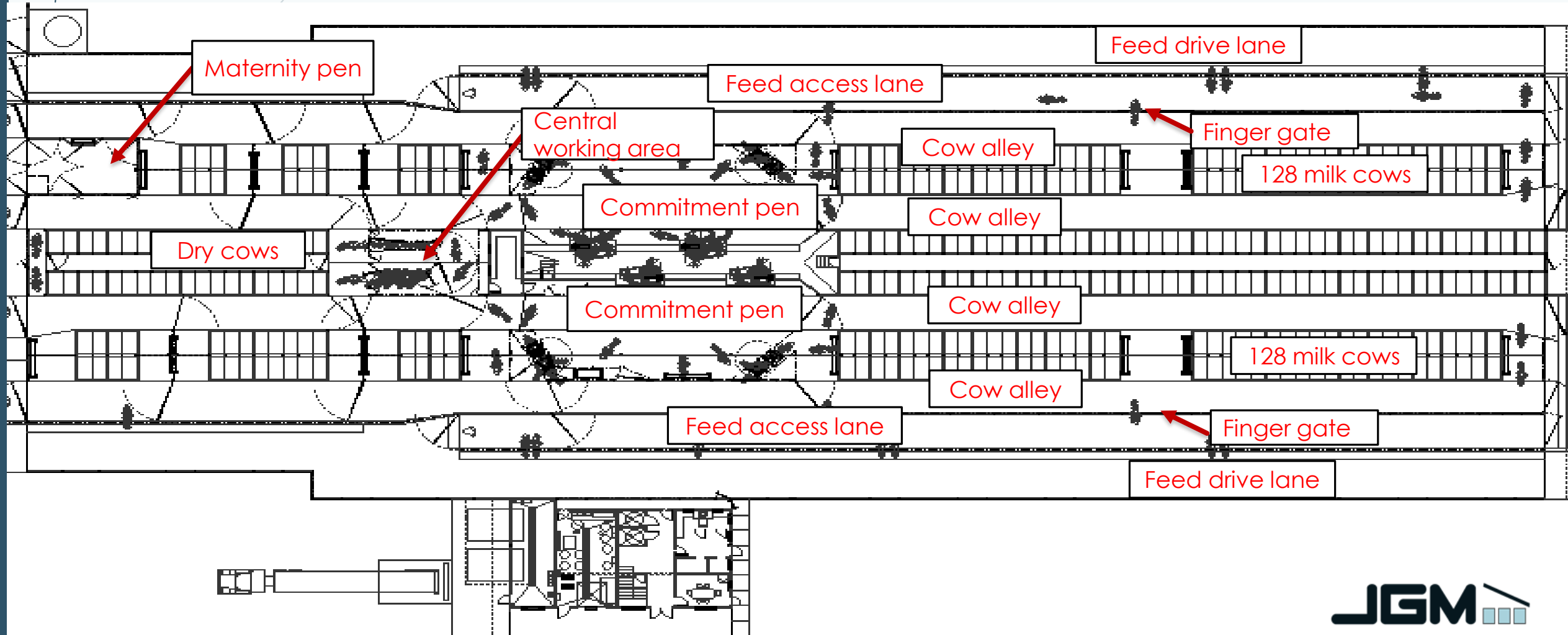

Retrofit - Hybrid Flow: Clemson University-Lamaster Dairy, Clemson, SC

- Existing Facility
 - Bedded pack
 - 126 Holstein cow freestalls
 - 55 Jersey cow freestalls

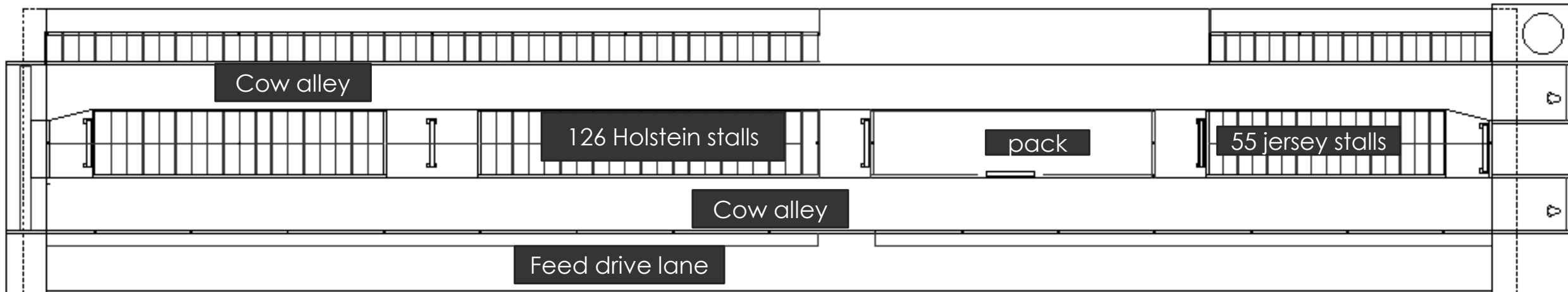

Retrofit - Hybrid Flow: Clemson University-Lamaster Dairy, Clemson, SC

- Retrofit Portion
 - (2) VMS units for Holsteins
 - (1) VMS unit for Jersey cows
 - Pre and post-selection sort gates for Holsteins
 - (1) dual purpose pre/post selection sort gate for Jerseys

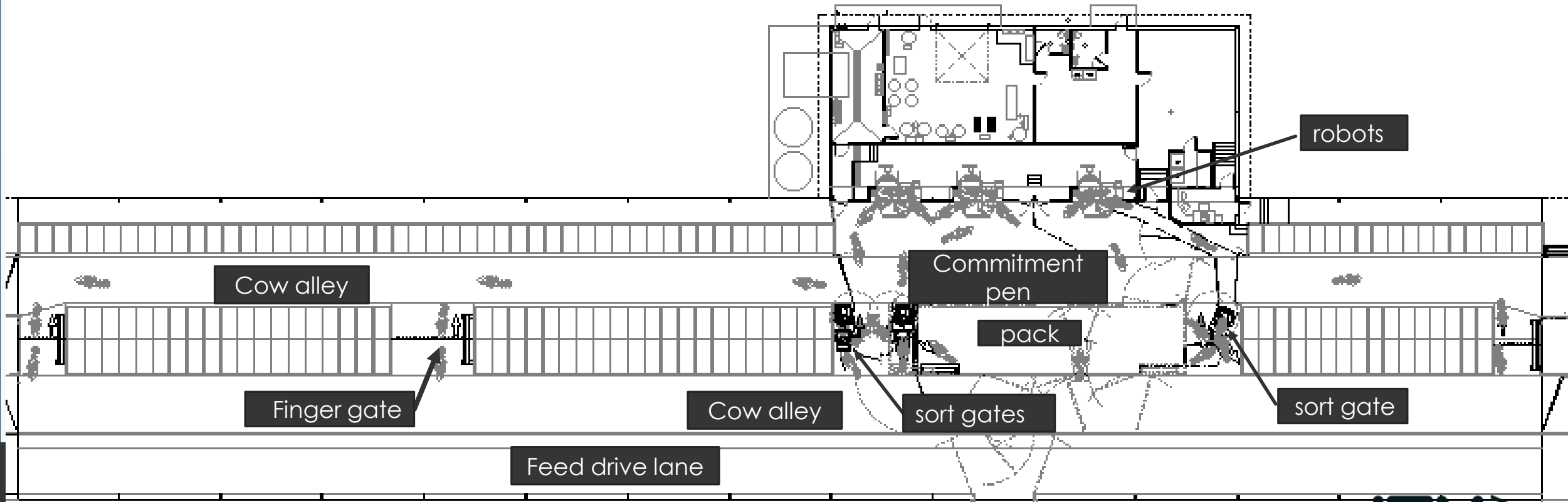

Retrofit – Free Flow: Hillcrest Farms-Dearing, GA

- Existing Facility
 - 4-row freestall barn with central feed drive
 - 182 stalls/side of barn
 - Outer travel lanes both sides of barn

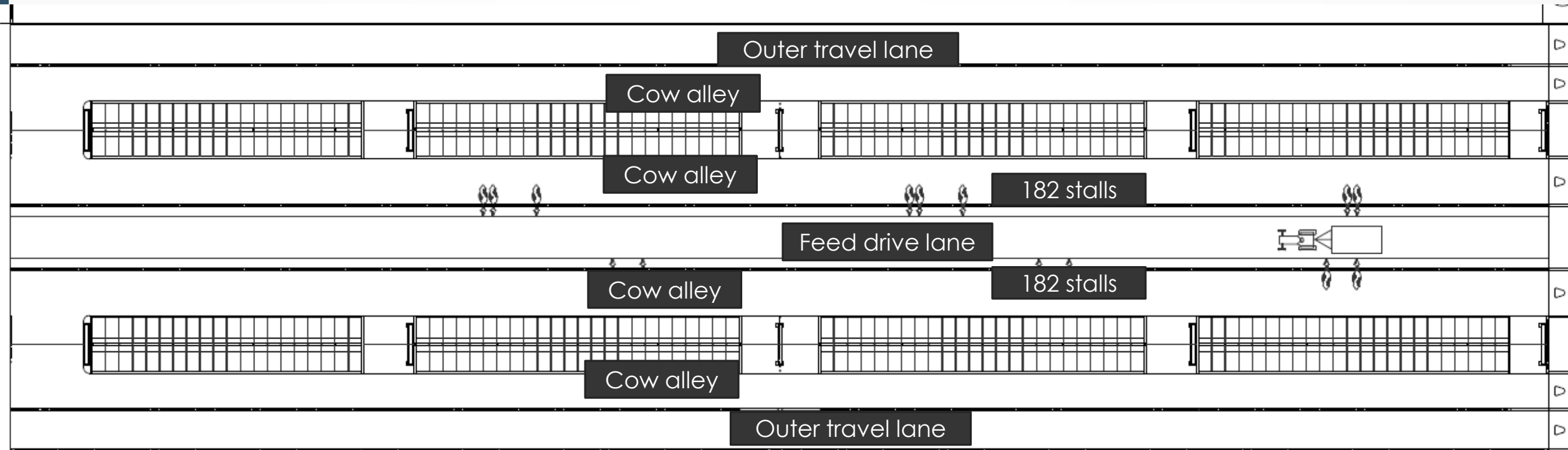

Retrofit – Free Flow: Hillcrest Farms-Dearing, GA

- Retrofit Portion-total milk herd of 325
 - (2) VMS units on north side for 142 stalls
 - (3) VMS units on south side for 182 stalls
 - Maternity building with 30 c/u stalls & bedded pack for 5 maternity cows
 - 40 existing stalls for dry cows

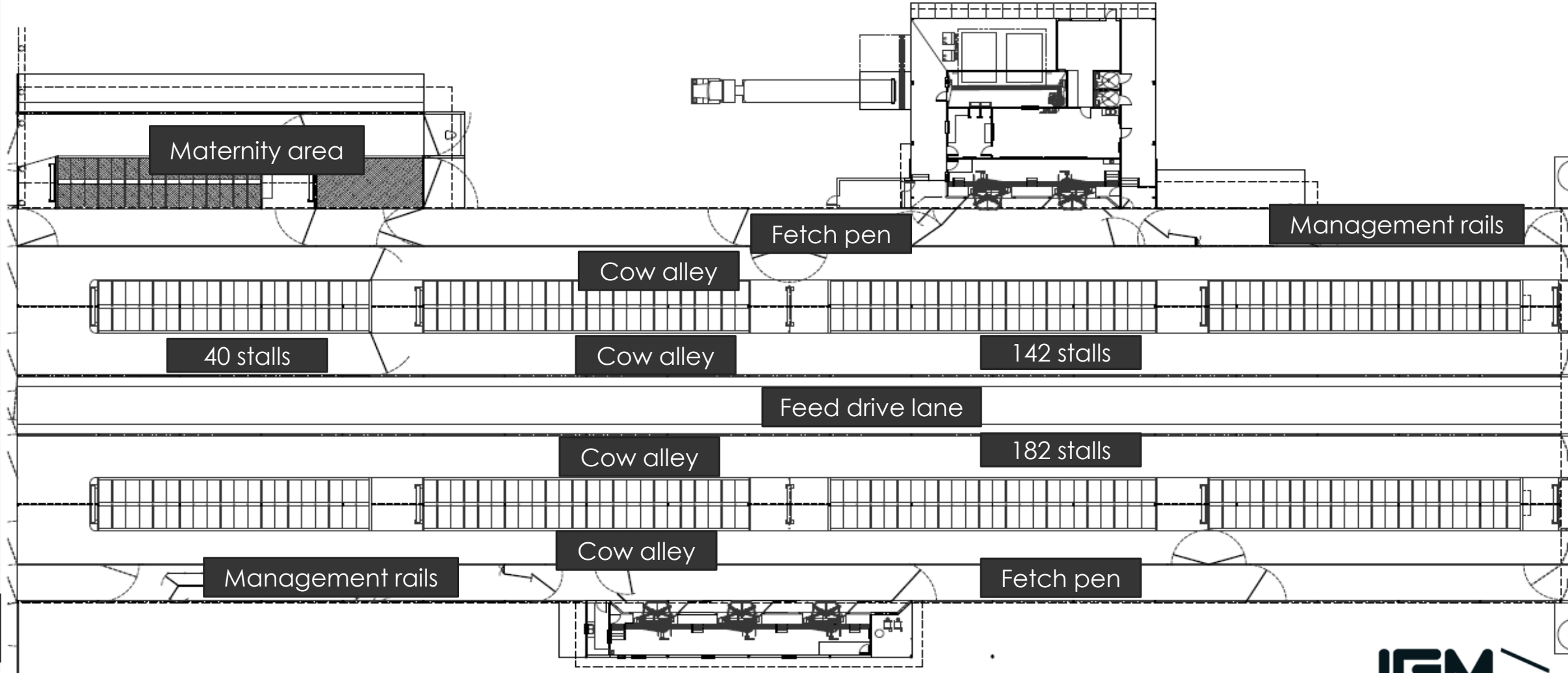



Is Robotic Milking Suitable for you?

- ▶ What is your preferred barn design/cow flow design?
- ▶ How do you want to manage your herd and people?
- ▶ What is your desired return on investment?

Questions/Comments?





SECURING THE DAIRY INDUSTRY'S FUTURE: ANTICIPATING & MITIGATING ACTIVIST THREATS

**HANNAH THOMPSON-WEEMAN, ALLIANCE VICE PRESIDENT OF
COMMUNICATIONS**



**MISSION: BRIDGING THE COMMUNICATION
GAP BETWEEN FARM & FORK**



ALLIANCE BOARD OF DIRECTORS

Alltech
Cattle Empire
Charleston | Orwig
Cooper Farms
Diamond V
Elanco Animal Health
Farm Journal
Genus- PIC/ABS
Hy-Line North America
Iowa Soybean Association
Merck Animal Health
Morning Fresh Farms
New Mexico State University
Nutrien
Smithfield Hog Production
Texas Cattle Feeders Association
Zoetis

American Farm Bureau Federation
American Feed Industry Association, *chair*
American National CattleWomen, Inc.
American Sheep Industry Association
American Veal Association
Dairy Management Inc.
National Cattlemen's Beef Association
National Chicken Council
National Corn Growers Association
National Pork Board
National Pork Producers Council
National Turkey Federation
North American Meat Institute
U.S. Poultry & Egg Association
United Egg Producers
United Soybean Board



WHY DO WE EXIST?



**THE FUTURE OF ANIMAL AGRICULTURE IS UNDER ATTACK
FROM ACTIVIST GROUPS WHO WANT TO END THE INDUSTRY.**

ANIMAL RIGHTS ACTIVISTS TARGET CONSUMERS, CUSTOMERS, POLICY MAKERS, INVESTORS...



TODAY'S ACTIVIST MOVEMENT

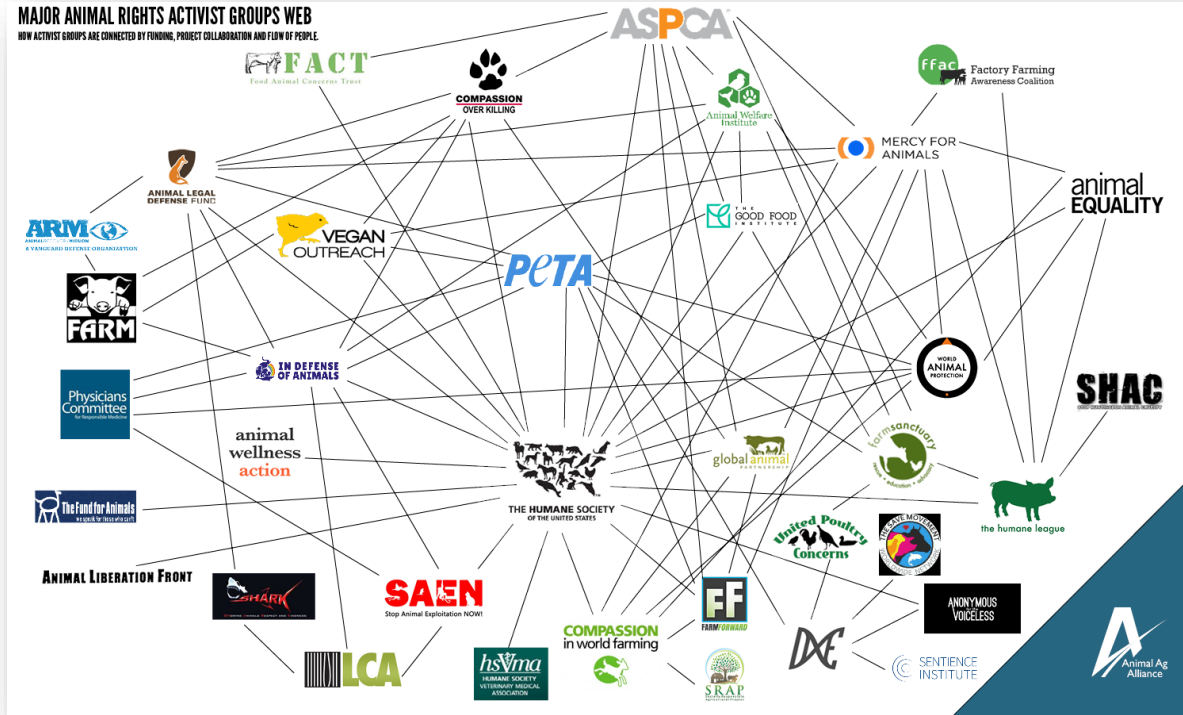

**\$4.3
BILLION+**

ACTIVISM IS BIG BUSINESS



The Humane League — General Support (2018)



Staff of The Humane League. (Photo courtesy of The Humane League)

Organization Name : [The Humane League](#)

Award Date : 8/2018

Grant Amount : \$10,000,000

Purpose : For general support.

Mercy For Animals — Broiler Chicken Welfare Corporate Campaigns (2016)	Mercy For Animals	Farm Animal Welfare	\$1,000,000	11/2016
Mercy For Animals — International Cage-Free Advocacy	Mercy For Animals	Farm Animal Welfare	\$1,000,000	8/2016
Mercy For Animals — Corporate Cage-Free Campaigns	Mercy For Animals	Farm Animal Welfare	\$1,000,000	2/2016

Organization Name : [Humane Society of the United States](#)

Award Date : 11/2016

Grant Amount : \$1,000,000

Purpose : To support new broiler welfare corporate campaigns

THEIR AGENDA: VEGAN/ANIMAL RIGHTS

“We’re preying on emotions to push our vegan agenda. We do not give our consent to enslave meat, we do not give our consent to murder.”

- *David Coman-Hidy, The Humane League, Nat’l Animal Rights Conf. 2016*

“Sometimes you have to be aggressive, and it doesn’t matter what form.”

- *Inga Fricke, Humane Society of the U.S., HSUS TAFE Conf. 2016*

"My goal is the abolition of all animal agriculture."

- *John “J.P.” Goodwin, HSUS, quoted on AR-Views discussion board*

“We are trying to destroy animal agriculture.”

- *Wayne Hsiung, Direct Action Everywhere, Nat’l Animal Rights Conf. 2016*



TACTIC: “UNDERCOVER” EMPLOYMENT & VIDEOS

Undercover video shows Florida dairy farm workers using blowtorches on COWS

Posted By [Xander Peters](#) on Fri, Dec 15, 2017 at 1:00 pm



Another
dairy f

Animal Recovery Mission (ARM)

- Owns “undercover training facility”
- 4 dairy & 1 egg “investigations” and videos in Florida in November – December 2017
- Targeted Publix Supermarket
- Encouraged viewers to avoid dairy and eat plant-based diet
- Now offering to partner with retailers to “investigate”

TACTIC: “UNDERCOVER” EMPLOYMENT & VIDEOS

JULY 18, 2019

New video shows animal living conditions at Fair Oaks Farms, more videos coming

Justin L. Mack, Vic Ryckaert and Kellie Hwang, Indianapolis Star | Published 9:48 a.m. ET June 12, 2019 | Updated 4:49 p.m. ET June 12, 2019

Warning: This video contains graphic footage.

Miami-based animal welfare group Animal Recovery Mission released another video documenting animal abuse at Fair Oaks Farms. Mykal McEldowney, IndyStar



New Undercover Video Shows Alleged Abuse at Another Dairy Farm

An investigation remained ongoing and interviews were still being conducted, according to authorities. Published Jul 23, 2019 at 5:13 PM | Updated at 5:23 PM CDT on Jul 23, 2019



TRENDING STORIES

...enes filmed last winter by an undercover investigator, revealing a pattern of neglect at Summit Calf Ranch (Ne-id owned by Tuls Dairy a supplier of Bel Brands, producer of Babybel.

...realizes the prolonged suffering of dozens of calves, whose ages range from one up to 150 days old, freezing to l with the wind chill. Repeated exposure to extreme temperatures resulted in frozen limbs, and the separation of me even died in agony.



Undercover Investigator: United States

Mercy For Animals - Los Angeles, CA

Apply Now

Objective:

To obtain employment at factory farms and slaughterhouses in order to document Investigators must be prepared to witness unimaginable cruelty and engage in intense manual labor while maintaining their composure and cover to gather information necessary and stop farmed animal abuse.

Primary Responsibilities:

- Conduct thorough research on various farmed animal welfare issues and agricultural practices and facilities
- Apply for and obtain employment in the animal agriculture industry, including factory farms, hatcheries, livestock markets, and slaughterhouses
- Using hidden cameras, thoroughly document conditions and practices in the referenced facilities, paying particular attention to animal welfare issues
- Maintain daily records and communications with the director of investigation course of investigations
- Review, compile, and transmit footage, photographs, and notes to the director of investigations
- Retain strict cover and confidentiality regarding all cases and any other sensitive information before, during, and after each case
- While undercover, meet or exceed all expectations of the agricultural facility maintaining cover and following all federal and local laws
- Be available to meet with law enforcement and provide testimony for all legal proceedings resulting from a case

Requirements:

- The highest level of personal integrity, intelligence, responsibility, and intestinal

x

Undercover Investigator (Animal Cruelty)

Mercy For Animals - Denver, CO

Apply Now

x

To obtain employment at factory farms and slaughterhouses in order to document conditions. Investigators must be prepared to witness unimaginable cruelty and engage in intense manual labor while maintaining their composure and cover to gather information necessary to expose and stop farmed animal abuse.

Primary Responsibilities:

- Conduct thorough research on various farmed animal welfare issues and agricultural practices and facilities
- Apply for and obtain employment in the animal agriculture industry, including factory farms, hatcheries, livestock markets, and slaughterhouses
- Using hidden cameras, thoroughly document conditions and practices in the above-referenced facilities, paying particular attention to animal welfare issues
- Maintain daily records and communications with the director of investigations during the course of investigations
- Review, compile, and transmit footage, photographs, and notes to the director of investigations
- Retain strict cover and confidentiality regarding all cases and any other sensitive information before, during, and after each case
- While undercover, meet or exceed all expectations of the agricultural facility while maintaining cover and following all federal and local laws
- Be available to meet with law enforcement and provide testimony for all legal proceedings resulting from a case

Requirements:

- The highest level of personal integrity, intelligence, responsibility, and intestinal fortitude
- Ability to operate independently in physically and emotionally grueling environments
- Willingness to travel extensively

UNAUTHORIZED VIDEOS/PICTURES

Drone on the Farm: An Aerial Exposé



What are factory farms hiding with "ag-gag" laws? I'll combine drone photography with investigative reporting to find out.

Created by
Will Potter

1,312 backers pledged \$75,064 to help bring this project to life.

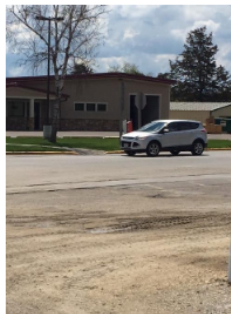

Suspicious vehicle at live receiving area

Alert Date: 04/21/2016

Location: Arcadia, WI, U.S.A.

Industry: Poultry

Activists Involved: Unknown

Active Alert

The Alliance has been notified of a suspicious vehicle with Minnesota license plates that was seen pulling away from a poultry company's live receiving area in Arcadia, Wisconsin, yesterday at 1 p.m.

Videos



Drones Expose
Milk Industry
Secrets

mercyforanimals
YouTube - Mar 14, 2017



Baby Cows -
Shocking Drone
Video Exposes
How The Dairy
Industry ...
KinderWorld.org Editor
Kinder World - Aug 11, 2018



Mercy For Animals
- Drones Expose
Milk Industry
Secrets

Facebook - Jul 1, 2018

DXE LAUNCHES “FRONTLINE SURVEILLANCE PROGRAM”

- Describes the program as “essentially open rescue but in a different way.”
- Says the purpose is to “to accumulate an extensive amount of investigatory footage, evidence, data...and basically all of this is to showcase that criminal animal cruelty is happening all the time, everywhere”
- References sending “documentation” to law enforcement, legislators and political figures
- Specifically mentions **dairy cows in extreme weather and cow/calf separation as some** of the standard industry practices that they want to show the public, law enforcement and legislators.
- They want law enforcement to take immediate action, want this “criminal animal cruelty” to be prosecuted. They also want the industry to know that efforts to “oppress” them will not work, and they want to inspire others to take action.

TACTIC: PROTESTS & “OPEN RESCUES”

Animal Rights Activists Stage Huge Protest At Petaluma Egg Farm

By Susie Steimle May 29, 2018 at 6:59 pm Filed Under: animal rights activists, Arrests, Direct Action Everywhere, egg farm, Petaluma, Protest



DXE Protest after Animal Liberation Conference May 29, 2018 –

- 500 Activists stormed Petaluma, CA Egg Farm
- Livestreamed 3 hour event
- Presented misleading “legal opinion” to gain access to farm
- Stole birds
- Trashed farm with litter, human waste
- 40 arrested



TACTIC: PROTESTS & “OPEN RESCUES”

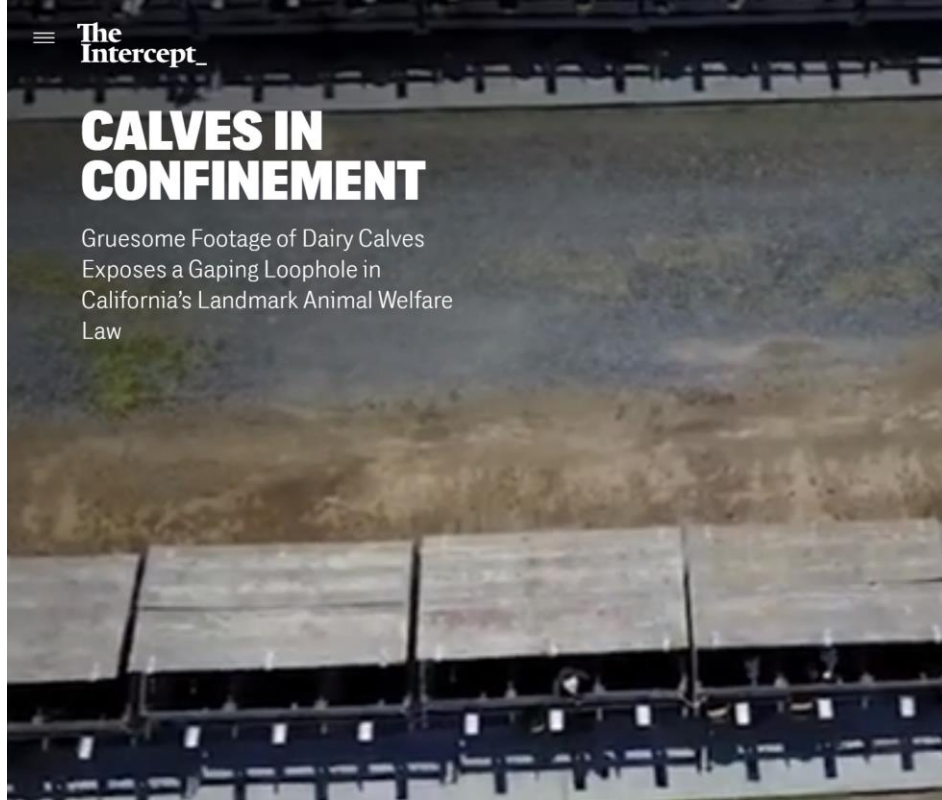

Costco's Graveyard

 Direct Action Everywhere - DxE

 Follow

 Like  Comment

 1.7K 361 C

TACTIC: PROTESTS & “OPEN RESCUES”

 Direct Action Everywhere - DxE
October 23 at 7:00 AM · 🌐

This farm dumped a LIVE baby cow in a graveyard, and the women who tried to save the baby are the ones facing felony charges
#CostcosGraveyard

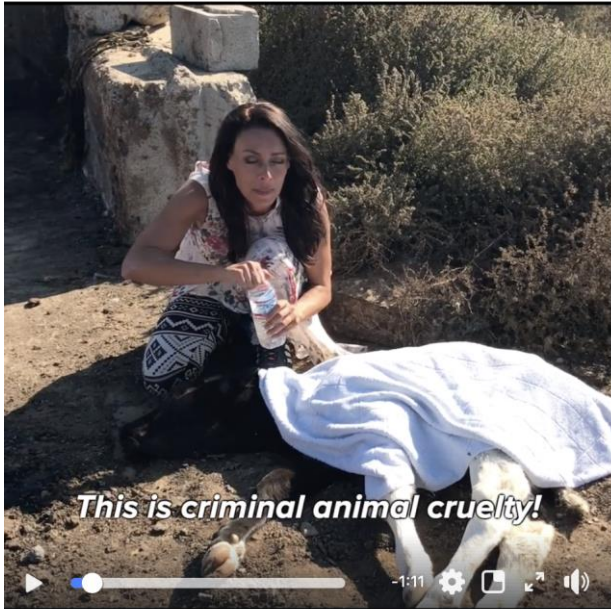

 Direct Action Everywhere - DxE was live.
October 21 at 5:43 PM · 🌐

BREAKING: Priya, Julianne, and Alicia found a baby cow who was sick and left in a dead pile at a massive dairy farm. They were taking the calf to receive vet care. But instead of helping them, the police ripped the baby from their arms and charged them with felony grand theft.

Now they're sitting in jail on \$30,000 bail and need YOUR help.



TACTIC: TARGETING TRANSPORT



Cheyenne Holliday

December 10, 2018 · 🌐



Terrified babies. Today I followed a truck carrying piglets who had just been taken away from their mothers to be sent to a confinement operation where they will live out the rest of their incredibly short lives before being sent to slaughter. I begged the driver and people running the operation to put me in contact with the person who could surrender or sell me at least one of these piglets. They gave me a phone number, which I called but received no answer. I tried to reach out to them on a heart level and explain why I was there and asked again if I could at least spend some time with them. We negotiated a bit and they agreed to let me stand outside of the truck while they were being unloaded. I captured these images and some videos. When they saw I was filming, I was asked to leave. I spend the next hour sobbing in my car. My head hurts, my eyes are dry and my heart aches. Please, I am begging YOU, stop this violence. Help me free these babies. Liberation for all involves us all. Need help going vegan? Message me.



TACTIC: EVENT DISRUPTIONS



Johanna Elizabeth is at [The Royal Agricultural Winter Fair](#).

November 6, 2018 · Toronto, ON, Canada · 🌐

Why [The Royal Agricultural Winter Fair](#)? Why disrupt events the way we do? Why not just educate people on why this is wrong?

The reason why we do this, and the question you should be asking is:

How would you want to be spoken for if you were the victim?

What would you do if it were you inside these cages, being pecked to death by your sisters? If it were you being manhandled and prodded around a ring to show how good your owners were at genetically manipulating life. If you were stuck on a transport truck, moments from a violent and painful death, with no way to escape?

Animals are individuals, just like us. They feel pain, suffer, and just want to live free of oppression. The same way that most people know their dogs and cats as individuals with a soul, I know that all animals are the same.

It's time to evolve. This violence and oppression is unnecessary. The Royal is about celebrating "farming's" past - but what about it's future?

Injustice cannot live forever, and their time is finally coming.

What can you do?

Step 1: Change yourself - go vegan and stop supporting this violence with your money.

Step 2: Take action - like [Direct Action Everywhere Toronto](#) and [Animal Rights Toronto](#) and join us at our next events!

[#ExploitationPlace](#)

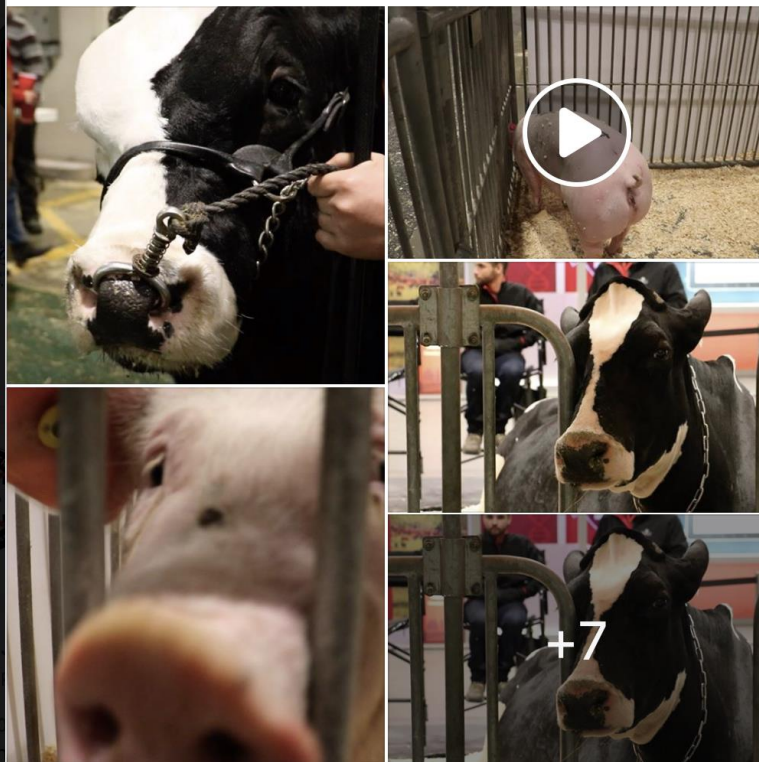

👍👎❤️ 52

49 Comments 36 Shares

RESTAURANT/RETAIL PRESSURE

“Driving Institutional and Corporate Change” – 2019 Animal Rights National Conference

- “We can create a more vegan world by adding institutional campaigns.” – Alan Darer, Mercy for Animals
- “We exist to end the abuse of animals used for foods.” – Kelly Myers, The Humane League
- “An incremental approach is used to gradually switch companies over to veganism.” – Myers
- “You want to put direct pressure on the decision makers in the company; know how the business functions and what will frustrate the decision makers the most.” – Myers
- “You don’t want to give your target time to catch its breath.” – Myers
- “We took over Ronald McDonald and made him into an evil animal abuser.” – Myers
- “We surround buildings so that employees have to see and feel guilt anytime they leave.” --Myers

RESTAURANT/RETAIL PRESSURE

Take action now



McDonald's has a chicken problem. Tell them to do better!

The chicken on the McDonald's menu comes from factory farms where the birds are bred to grow large.

chronic pain, leg deformities, and heart attacks.

McDonald's has the power to reduce the suffering of many of their biggest competitors—including the likes of which have already committed to addressing these critical

Learn more, sign and share the petition, and tell them to step up for chickens.

TAKE ACTION NOW »



the humane league™

Humane Society of the United States
— Broiler Welfare Corporate Campaigns



Broiler chickens. (Photo courtesy of the Humane Society of the United States)

Organization Name : [Humane Society of the United States](#)

Award Date : 11/2016

Grant Amount : \$1,000,000

Purpose : To support new broiler welfare corporate campaigns

VICTORIES

Millions of farm animals have been impacted by changes championed by The Humane League and our supporters. These are some of the companies that have improved conditions for farm animals as a result of a campaign by The Humane League.



CAGE-FREE EGG POLICIES - RETAILERS

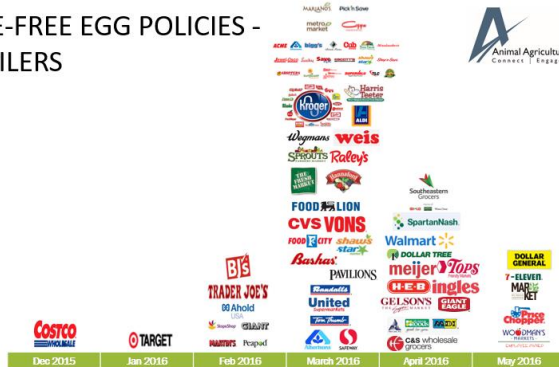

BROILER WELFARE POLICIES



ANTIBIOTIC USE POLICIES



Sow Housing Policy Announcements



Provided by the National Pork Producers Council

TACTIC: USING CLIMATE CHANGE TO ENCOURAGE REDUCTION OF MEAT CONSUMPTION



THE HUMANE SOCIETY OF THE UNITED STATES

- NEWS
- VIDEO
- ANIMALS
- OUR WORK
 - Campaigns »
 - Issues A-Z »
- MAGAZINES
- ABOUT US
- WAYS TO GIVE

We're the nation's most effective animal protection organization.



Miguel Villarreal went meatless after his 10th beef recall as a school food service director in a time span of 20 years. © Don Priorard



Meatless

Share:  Facebook  Twitter

Food service goes meatless at schools, universities and Meatless Monday program encourages environmental sustainability

Launching on January 17, 2019 —

The EAT-Lancet Commission on Food, Planet, Health

Can we feed a future population of 10 billion people a healthy diet within planetary boundaries?

[Read more](#)



food system limits

oz, Keith Wiebe, Benjamin Leon Bodirsky, Herrero, Kimberly M. Carlson, Malin Jonell, k, Peter Scarborough, Mike Rayner, Brent ohan Rockström & Walter Willett

The EAT-Lancet Commission on Food, Planet, Health brings together more than 30 world-leading scientists from across the globe to reach a scientific consensus that defines a healthy and sustainable diet.

The Commission is delivering the first full scientific review of what constitutes a healthy diet from a sustainable food system, and which actions can support and speed up food system transformation.

TACTIC: ANIMALS & RELIGION



THE HUMANE SOCIETY OF THE UNITED STATES

NEWS

VIDEO

ANIMALS

OUR WORK

MAGAZINES

ABOUT US

Overview »

Leadership »

Departments and Affiliates »

FAITH OUTREACH

VIDEOS

In Your State »

Events »

DONATE

Faith Outreach

Share: [Facebook](#) [Twitter](#) [Email](#) [Print](#)

The Faith Outreach program of The Humane Society of the United States seeks to engage people and institutions of faith with animal protection issues, on the premise that religious values call upon us all to act in a kind and merciful way towards all creatures.

DONATE
Spread the message of compassion and mercy for animals

[GIVE](#)

SIGN UP

TAKE ACTION



Read Every Living Thing

Every Living Thing: How Pope Francis, Evangelicals and Other Christian Leaders Are Inspiring All of Us to Care for Animals is an inspiring collection of teachings on animal protection from Christian leaders. Hand-picked by Christine Gutleben, Senior Director of Faith Outreach for The HSUS, *Every Living Thing* is a perfect companion to your daily spiritual reflection, informal discussion with friends or Sunday School studies.



ANIMALS ARE NOT OURS
TO EAT, WEAR, EXPERIMENT ON, USE FOR ENTERTAINMENT, OR ABUSE IN ANY OTHER WAY. ▶



Home Features Videos Action Blog Issues Living Shop Investigations Media Center About PETA [Donate Now](#)

PETA / CAMPAIGNS

Jesus People for Animals



© iStock.com/locke_1rd

Reasons Why 'The Daniel Plan' May Kick-Start Your Kind New Life

Have you heard of "The Daniel Plan"? Whether you're Christian or not, there are a bunch of great reasons to try it.

[READ MORE >](#)



© iStock.com/Bryndak

Actor James Cromwell: "Give Pigs a Break This Easter"

"When I made the movie Babe, I learned how smart and sensitive pigs are," Cromwell says in a new PETA radio ad running in "Bible-minded" cities this week.

[READ MORE >](#)

Connect With PETA

[Like 5.3M](#) [Follow](#) [1.06M followers](#)

SUBSCRIBE TO PETA E-NEWS

[SUBSCRIBE](#)

Search This Section

[SEARCH](#)

Recent Posts

[2018: The Time for Animal Rights is Now](#)



"Whatever you do unto the least among my brothers and sisters, you do as unto me..."
Matthew 25:40



SCRIPTURE BEING VEGAN NEWS FEATURES HELPING ANIMALS DONATE [Q](#)

All God's Beings Deserve Kindness and Compassion This Season

We can celebrate the lives of every being and answer God's call to be merciful by extending our compassion to the holiday table.



Photo by Terry Cummings at PETA's Spring Animal Sanctuary

Animal Agriculture Alliance
Connect | Engage | Protect

“WHAT WOULD JESUS REALLY EAT?”

A new book, “What Would Jesus Really Eat? The Biblical Case for Eating Meat,” is now available to help arm farmers, ranchers and others in the animal agriculture industry with the information they need to have informed conversations about the complex subject of religion and eating meat.

The book, edited by Palm Beach Atlantic University’s Wes Jamison, PhD and Paul Copan, PhD, looks at what the Bible has to say about using and eating animals from several different perspectives and tackles topics including the challenges to Christian meat-eating, human exceptionalism and humanity’s dominion over other living creatures.

Copies of the book can be purchased from the Alliance at a discounted rate.

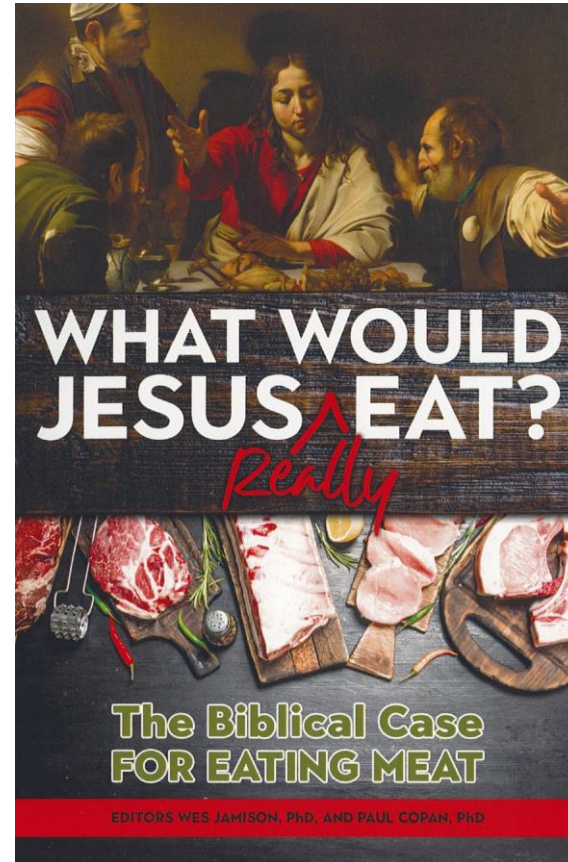



WHAT CAN WE DO ABOUT IT?

START ON THE FARM- “YOUTUBE PROOF”



- Implement science-based animal care and environmental policies
- Seek advice from experts
- Strive for continuous improvement
- Create a culture of care and professionalism for all job levels
- Train employees thoroughly and have refresher courses; zero tolerance for mistreatment of animals
- Conduct self audits; 3rd party audits



ANIMAL CARE AGREEMENT

Animal Care Employee Agreement

Employee Name _____ Date _____
(Print)

1. Fresh feed must be made available on a daily basis. If not, correct problem or contact supervisor.
2. All lights should be in working order. If lights are not in working order correct problem or contact supervisor.
3. Air should be moving through the house at all times. If fans, air inlets or curtains are not in working order, correct the problem or contact supervisor.
4. Water must be available at all times. Water supply issues must be corrected or brought to the attention of the supervisor.
5. Shelter should be appropriate for bird's age, type, and production. Correct the problem or notify supervisor if you should see equipment that is broken or worn out to include cages, nest boxes, perches, litter areas, netting, and fencing.
6. Biosecurity rules and standard animal welfare practices need to be obeyed. If biosecurity rules are not being followed by other employees contact supervisor.
7. Safety rules of the farm must be followed. If the safety rules of the farm are not being obeyed contact the supervisor.
8. Injured or sick birds need to be taken care of. Contact supervisor if you have questions about the action to be taken with such birds.
9. Proper euthanasia of sick, injured or cull birds will be conducted by a trained employee. Contact supervisor if you are unable to perform this task.
10. Dead birds will be removed from bird living area on a daily basis and properly disposed of. Contact supervisor if procedure is not being followed by all employees.
11. All birds (live or dead) will be handled with respect and dignity. Proper handling and catching methods to minimize stress must be followed. Any person not adhering to this should be reported to



PROFESSIONAL CULTURE



COOPER FARMS C.A.R.E.S.

COMPREHENSIVE ANIMAL RAISING AND ENVIRONMENTAL SYSTEMS

At Cooper Farms, being responsible caretakers of our animals and land is always at the forefront.

We continue to strive for better, more sustainable production practices and constant improvements for the utmost care of our animals.

Animal Care

Since 1938 Cooper Farms has taken the lead in providing safe and humane environments for our animals. Over the years, Cooper Farms has grown and diversified. From raising only a handful of turkeys in 1938, to starting a small hatchery, today the company not only raises turkeys, but also raises hogs as well as chickens for table eggs. Cooper Farms



We also have
Auditor Certif
emp
daily

Our
desig
a cor
Our

COOPER FARMS C.A.R.E.S.

COMPREHENSIVE ANIMAL RAISING AND ENVIRONMENTAL SYSTEMS

At Cooper Farms, it is our mission to do things better today than we did yesterday.

Biosecurity at Cooper Farms

Prevention is the foremost goal of our biosecurity program.

Our controlled environments reduce the threat of disease-

causing agents from entering our farms and affecting our animals. Our turkey and hog breeding farms require workers to shower in and out, while growing farms require special garments prior to entry. Entry to all farms is restricted with signs prominently displayed. To further reduce the risk



Environmental Care

Cooper Farms is proud of our long tradition of environmental stewardship. It is our continuing goal to provide the best products while incurring the least environmental impact on surrounding farms, waterways and communities.

Our Certified Livestock Management staff is expertly trained by the Ohio Department of Agriculture. We encourage our family farm producers to develop a Comprehensive Nutrient Management Plan for proper distribution of animal waste. A sophisticated distribution system for animal wastewater applies the correct

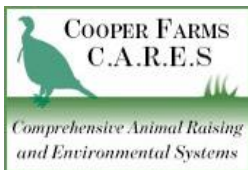



GENERAL SECURITY TIPS

- Locks/keypads on doors and gates
- Motion-sensor lighting
- Cameras if feasible
- No Trespassing signs
- Process for employees to determine if someone is a legitimate visitor
- Report suspicious activities or visitors to the Alliance, state association, co-op, local law enforcement



Lewis Bernier

May 22 · 🌐



Wayne Hsiung and 51 others

2 Comments



Like



Comment



Share



FARM SECURITY - HIRING

- **Employment application**
 - Use a written application form for all employees and require a signature
 - Work with local legal counsel to ensure compliance with federal and state laws
- **Keep an eye out for red flags**



REMEMBER...

- **NEVER** take an application at face value. **ALWAYS** check an applicant's references!
 - Never call a cell phone for a company reference, always dial the company directly and ask to be transferred to the referenced employee.
 - Be vigilant!
 - Search for all applicants online to see if they have public social media profiles (Facebook, Twitter, LinkedIn, Instagram, etc.) or websites/blogs. Look for any questionable content or connections to activist organizations.



TRUST YOUR GUT

- If something does not seem right, explore it further.
- Never take employees into parts of your operation where they wouldn't normally have access—even if they tell you "I've always wanted to see how that was done."
- Procedures involving pain and/or dealing with moving sick and injured animals should be done by your most senior employees and NOT your new hires.



FARM SECURITY - VISITORS

- **Ensure all of your family members or employees know how to handle an unexpected visitor**
 - Don't be afraid to ask for credentials or verification of identity
 - Do not take them at their word – verify all claims with proper contacts
 - Gather as much information as possible
 - Immediately report any suspicious activity to your state association
- **Escort visitors at all times**



FARM SECURITY - TRANSPORT

- **Notify transport companies/drivers about potential for activist activity**
 - Number one guideline – DO NOT ENGAGE
 - Contact law enforcement if approached
 - Make sure trucks are locked
- **Be mindful of safety concerns**
- **Do not allow anyone to access trucks for any reason**



FARM SECURITY - PROTESTS

- **Avoid confrontation & engagement**
 - Keep your cool – you are probably being livestreamed/recorded (have someone look for a livestream and watch it)
 - Do not respond to inquiries or answer questions
- **Contact law enforcement immediately**
 - Let them handle any conversations with protesters
 - Make sure they are familiar with animal welfare laws in your state/area – make sure you are familiar with them!
- **Turn the camera on them**
 - Record protesters. Write down their vehicle descriptions and plate #s



FARM SECURITY - PROTESTS

- **Make sure EVERYONE knows policies and procedures**
 - Neighbors, employees, family members, vendors
- **Know your property boundaries & local laws**
 - Usually, people can assemble on public property but cannot cross onto private property (in some places they need a permit to assemble)
 - They cannot be in the road or blocking entrances/exits from your property (they will try to do this to get drivers to talk to them)



FARM SECURITY - EVENTS

- Have a “Principles of Animal Care” statement that visitors/exhibitors must read and sign
- Designate spokespeople and prepare messaging
- Contact law enforcement and local officials to raise awareness of potential activist disruptions
- Ignore disruptions/protests





THREAT MONITORING

- **Watch for warning signs**
 - Increase in requests for information
 - Calls/letters
 - Unusual interest in gaining employment
- **Monitor media and social media**
 - Google Alerts
 - Check local/national activists' Facebook regularly



PUT A FACE ON ANIMAL AGRICULTURE



- People are hungry to learn about where their food comes from
- Help them get answers from people who work in agriculture instead of the internet or activists
- Media training
- Community engagement
- Share on social media
- Be willing to answer genuine questions



PUT A FACE ON ANIMAL AGRICULTURE

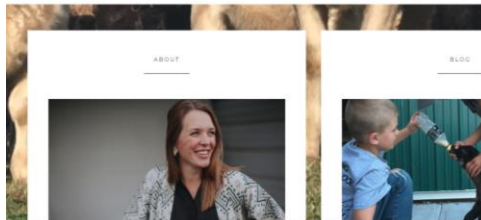

As Seen On





WHAT IS THE ALLIANCE DOING?



MEDIA ENGAGEMENT

meatingplace

HOME NEWS ARCHIVE RESOURCES CLASSIFIED SUBSCRIBE ADVERTISING

ANIMAL AG WATCH BY HANNAH THOMPSON
Hannah Thompson is the communications director for the Animal Agriculture Alliance.

Yet another documentary aims to skewer animal ag or the fork



NEWS ▾ MARKETS ▾ WEATHER ▾ MANAGEMENT RESOURCES ▾ AUDIO + VIDEO

Stuff Animal Rights Activists Say: 2018 Edition

Hannah Thompson-Weeman,
Communications Director, Animal
Agriculture Alliance

July 17, 2018 09:03 AM



Greenwire THE LEADER IN ENERGY & ENVIRONMENTAL POLICY NEWS

AGRICULTURE:

Industry alliance answers critics of large livestock farms

Marc Heller, E&E reporter

Published: Tuesday, June 28, 2016

Striking back against critics of large-scale livestock farms, the Animal Agriculture Alliance says farms raising hogs, chickens and cattle use far less land and water than they did decades ago, among other improvements, even as they produce more food.

PORK Network

Be prepared: Activists don't play fair at events and expos





INFLUENCER ENGAGEMENT





POSITIVE RESOURCES ON KEY ISSUES

THE TRUTH ABOUT WHY MEAT CONSUMPTION IS ESSENTIAL FOR OPTIMAL HEALTH

BY: JENNIFER M. LEHESKA, PH.D., R.D., L.D. - 2014

When it comes to diet and nutrition it seems that everyone is mad about meat these days for one reason or another. Red meat became the red-headed stepchild in the American diet due to its association with saturated fat after early animal and human studies (1950-60's) established a positive correlation between saturated fat intake and heart disease risk factors. This led to a nationwide fat scare that became the basis of the dietary recommendations in the U.S. over the past 50 years. This combined with the growth of animal activist groups working to turn American's to a vegetarian or vegan lifestyle has caused additional fear and confusion for U.S. consumers.

[Read More](#)

SUSTAINABILITY

The topic of responsible and sustainable animal agriculture has received a lot of attention in recent years, but these concepts are nothing new to the American farmer. Given the rise of social media and increased interest in food production by consumers, the people asking questions about sustainability are not just neighbors, friends and relatives, but include audiences around the world. This puts animal agriculture under increased scrutiny and means that farmers have to put far more emphasis on the social side of sustainability than ever before.

ISSUES

- Animal Welfare
- Antibiotic Use
- Sustainability
- Nutrition
- Legislation



This report highlights how the animal agriculture industry shares the same values as today's consumer with its never-ending commitment to animal care, environmental stewardship, responsible antibiotic use, food safety and nutrition.

- HOME
- ABOUT
- ISSUES
- INITIATIVES
- NEWS
- RESOURCE CENTER
- SUPPORT US

ANIMAL WELFARE

Farm families take the ethical obligation of providing the best quality care to their animals very seriously. Although farm size and type of production practices may vary, one thing farmers and ranchers have in common is the commitment to caring for their animals. We help farmers, ranchers and others in the industry communicate about their continuous improvements made in animal welfare.

To promote animal welfare and produce meat, poultry, milk and eggs of the highest quality, the Alliance recommends adherence to animal care guidelines that are outlined by each species group individually. Each group's program is outlined and linked below.

ISSUES

- Animal Welfare
- Antibiotic Use
- Sustainability
- Nutrition
- Legislation

Beef | The Beef Quality Assurance (BQA) program is a...

The Beef Quality Assurance (BQA) program is a nationally coordinated, state-specific program that provides cattle farmers and ranchers in every segment of the industry the principles, tools and education to ensure proper cattle care and raise the best quality beef possible.

Sheep | The Sheep Care Guide, sponsored by the...

Pork | The Pork Checkoff's Pork Quality Assurance® Plus...

Safe Feed, Safe Food | The Safe Feed, Safe Food (SF/SF) Certification Program...





MONITOR: MEDIA, LEGISLATION & ACTIVIST ACTIVITY

LEGISLATION

The Alliance closely monitors legislation that may impact animal agriculture at the state and federal level. State legislative measures dictating animal care are often lobbied for by activist organizations and have the potential to impact farmers' and ranchers' ability to provide safe, nutritious and affordable animal products for all.

ISSUES

- Animal Welfare
- Antibiotic Use
- Sustainability
- Nutrition
- Legislation

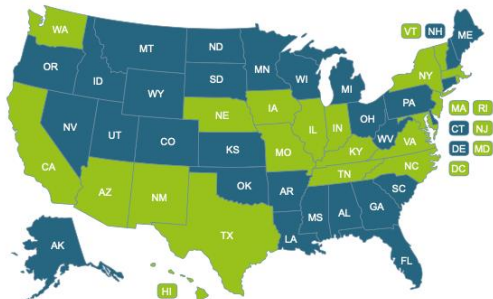

States in **GREEN** have pending legislation.

States in **BLUE** have past legislation.



CLICK ON A STATE TO VIEW
PAST AND PENDING
LEGISLATION.

NEWS

The Alliance works hard to be your one-stop-shop for news related to all things animal agriculture. Every day, our staff combs through hundreds of news stories and highlights the most relevant in the following areas: Alliance in the News; Animal Welfare; Animal Rights Activists; and Legislation.

Today's NewsClip Feed

11/04	CNBC	To satisfy high demand for meatless meat, Impossible Foods hired these employees—and they aren't in the food industry
11/03	SFGate	Rural Brazilian schools went vegan, then community revolted
11/03	Washington Examiner	Who's afraid of wild horses?
11/02	Fox 8	Macy's and Bloomingdale's will stop selling fur products in 2021
11/01	The Hill - Blogs	In this rare bipartisan moment, will our government do what's right for wild horses and burros?
10/31	Forbes	Why Tofurky Takes Its Loyalty To The Produce Department Seriously
10/25	FOX 47 News	Michigan Senate votes to delay cage-free ban for hens
10/23	USA Today	House unanimously passes bipartisan bill to make animal cruelty a federal crime
10/17	National Agri-Marketing Association	NAMA Fall Conference Sets Records in St. Louis
10/17	Forbes	How To Grow Your Brand By Thinking Bigger About Your Audience



ACTIVIST MONITORING & SECURITY RESOURCES

- Group profiles
- Conference reports
- Book and movie overviews
- Advice for protests
- Farm security recommendations

"NO TRESPASSING" SIGNAGE 101

[View Resource](#)

Trespassers, including ones affiliated with animal rights activist groups, can be a nuisance as well as a liability. Signs should be posted to prevent trespassing, but it is important to know specific state trespassing signage laws.

PREPARING FOR ACTIVIST PROTESTS ON FARMS



On May 29, 2018, a group of 500 animal rights extremists descended upon a California egg farm, destroying more than 35 hens. After law enforcement got involved, around 40 activists were arrested. Similar incidents have occurred since May, with the potential for more. The following resources are available to anyone affiliated with a farm, processing plant or other agricultural facility. Review these resources and prepare to potentially be targeted with similar tactics.

GREENPEACE

Headquarters: Washington, D.C.
Website: <http://www.greenpeace.org/usa>
Year Founded: 1987

Total Expenses	*\$10,149,201
Contributions and Grants	*\$11,461,261
Total Assets	*\$4,783,679

*Financial information provided by the organization's 2014 990 form (8/6)

Mission:
"Greenpeace is an independent campaigning organization, which uses non-violent, creative confrontation to expose global environmental problems, and to force the solutions which are essential to a green and peaceful future."

Group Profile: Key Environmental Groups

PCRM Physicians Committee for Responsible Medicine

Headquarters: Washington D.C.
Website: www.pcrm.org
Year Founded: 1985

Total Expenses	*\$11,861,610
Contributions and Grants	*\$10,913,171
Total Assets	*\$12,788,022

*Financial information provided by the organization's 2012 990 form (6/6)

Mission:
"Promote preventive medicine, conduct clinical research, and encourage higher standards for ethics and effectiveness in research."

Major programs:

Key Staff:

Group Profile: Key Consumer Groups



Headquarters: Norfolk, VA
Website: www.peta.org
Year Founded: 1980

Total Expenses	*\$64,212,563
Contributions and Grants	*\$43,332,789
Total Assets	*\$19,639,054

*Financial information provided by the organization's 2012 990 form (8/6)

Mission:
"PETA operates under the simple principle that animals are not ours to use. We are not for entertainment. PETA believes that animals have rights and deserve to have their best interests, their own considerations, regardless of whether they are useful to humans."

Major programs:

Key Staff:

Group Profile: Key Animal Groups



2020 STAKEHOLDERS SUMMIT

May 7-8 | Arlington, VA







It's one thing to talk about engaging in the public dialogue about animal agriculture. But what really makes the Stakeholders Summit special are the actionable tools that attendees walk away with. Attendees will leave the 2020 Summit primed and prepared with the tools they need to take action and be part of any and all conversations that could impact the future of animal agriculture and their business.



MORE DETAILS: [SUMMIT.ANIMALAGALLIANCE.ORG](https://summit.animalagalliance.org)

STAY IN THE KNOW

Follow us and share our posts!

-  Snapchat: AnimalAg
-  Facebook: Animal Agriculture Alliance
-  Twitter: @AnimalAg
-  Instagram: @AnimalAgAlliance
-  Pinterest: Animal Agriculture Alliance
-  LinkedIn: Animal Agriculture Alliance
-  Blog: AnimalAgEngage.com

Sign up for our newsletter:
AnimalAgAlliance.org



Animal Ag Alliance

CONNECT ENGAGE PROTECT



Alliance Link

May is one of our favorite months here at the Animal Ag Alliance. May usually brings warmer days, more sunshine and blooming flowers, but our favorite thing about May each year is our Stakeholders Summit. The 2019 Summit – “A Seat At The Table” – is sure to be another outstanding few days of coming to the table with leaders from throughout the food chain to network and take action to secure the future of animal agriculture. I just finished a round of preparation calls with some of our speakers, and I’m very excited about the lineup. They are full of energy, subject matter expertise and fresh ideas. I can’t wait for you to hear from them!

I also can’t wait to see and catch up with so many of our members and supporters. We have 325 attendees registered, making this the largest Summit yet. There are still seats at the table available – online registration will be open through Monday. If you aren’t able to join us in person in Kansas City, we will once again be offering a livestream of the sessions on Wednesday, May 8th. [Let us know](#) if you’d like to receive the livestream link next week. You can also follow along with the conversation on social media using #AAA19.

Hope to see you soon in KC!

Hannah
@BuckeyeHannah



THANK YOU



HANNAH THOMPSON-WEEMAN
VICE PRESIDENT OF COMMUNICATIONS

@BuckeyeHannah

HThompson@animalagalliance.org

MEET THE REST OF OUR MIGHTY TEAM ONLINE AT
animalagalliance.org/about/staff/

